



PRODUCT SPECIFICATION

TWS IP65 L7 WIRELESS



INTRODUCTION

The Twinspot IP65 L7 Wireless offers a flexible emergency lighting solution with minimal energy consumption and the reliability of an LED source eliminating the need for lamp replacement. The Twinspot IP65 L7 Wireless also incorporates a Lithium battery for extended lifetime, warranty and reduced maintenance costs. With a polycarbonate IP65 housing the Twinspot IP65 L7 Wireless is robust and resistant to dirt, dust and water ensuring it is suited to a wide range of applications such as warehousing, manufacturing and industry. The Twinspot IP65 L7 Wireless offers compatibility with both our Reacta-Link and Reacta-Control emergency systems offering automated emergency testing and reporting of results substantially reducing the ongoing maintenance costs of your emergency installation by eliminating the need to manually test luminaires and record the results.

**UK
CA** CE IP65 IK08

APPLICATION

- Canteen
- Commercial / Offices
- Corridor
- Education
- Exterior
- Food Production
- Healthcare / Social Housing
- Hotel / Leisure
- Industrial / Manufacturing
- Kitchen
- Office
- Parking / Exterior
- Retail
- Stairwell
- Store Room
- Toilet
- Transport
- Warehousing

SPECIFICATION

CONSTRUCTION

- Housing: Injection moulded polycarbonate
- Finish: Matt white
- Diffuser: Injection moulded clear polycarbonate
- IK08
- IP65

ENVIRONMENTAL

- Every luminaire is labelled with a unique ID number allowing easy identification of spare parts for the lifetime of the product.
- UK based manufacturing providing local support throughout the product lifetime and minimising transportation miles.

EMERGENCY

- Optional Reacta-Link wireless emergency for automated centralised reporting.
- Optional Reacta-Control wireless emergency for automated centralised reporting.

INSTALLATION

- Suitable for trunking installation
- Suitable for surface installation

IMAGES

PRODUCT IMAGES



TECHNICAL

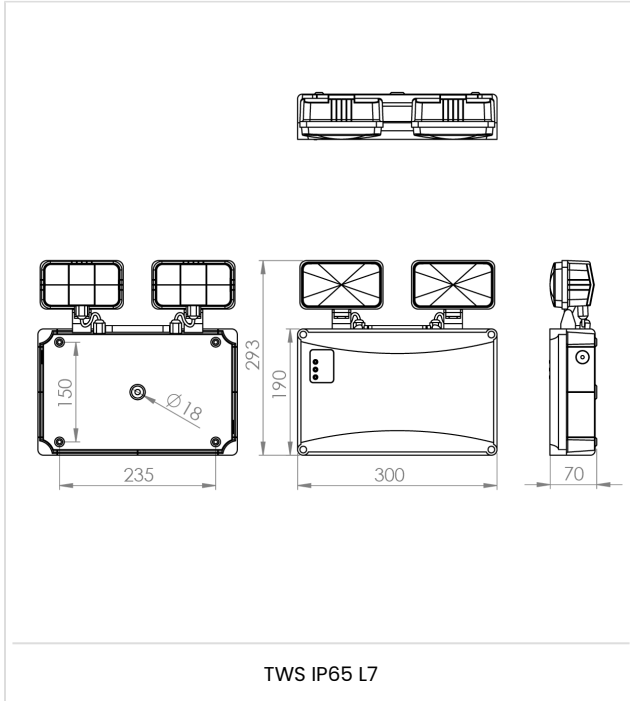

WARRANTY

At Dextra our commitment to service has been at the forefront throughout our history spanning more than forty years in the UK lighting market. Our service ethos extends beyond design and delivery, we believe supporting your installation throughout the warranty period is equally crucial, whilst the strength and longevity of Dextra Group provides peace of mind that our warranty will be supported throughout.

The Dextra range is supplied with a five year warranty commencing from the date of delivery. During the first three years defects will be repaired on site and the warranty will include both parts and labour. For the final two years drivers, emergency modules, wireless modules, sensors and LED circuits will be supplied free of charge to replace defective components, labour and other associated costs are not included.

Certain ranges and components are subject to exemptions:

- ▶ Lithium batteries are provided with a five year warranty. During the first three years defects will be repaired on site and the warranty will include both parts and labour. For the final two years replacement batteries will be supplied free of charge to replace defective components. Five year warranty became effective as of 03/02/25, Lithium emergency luminaires supplied prior to this date are supported with a three year on site warranty only. Labour and other associated costs are not included. Nickel Metal Hydride and Nickel Cadmium batteries are provided with a one year warranty for parts and labour.
- ▶ Emergency luminaires including AME2, EXI LED, EXI3, HBE3, HBE4, OAT2 LED and Twinspace are supplied with a one year warranty for parts and labour. Lithium variants suffixed with the 5YR part code, the Autotest emergency with the LA3 part code and wireless variants with LA3RC or LSTR part codes are supplied with a five year warranty. For these extended warranty variants for the first three years defects will be repaired on site and the warranty will include both parts and labour. For the final two years replacement batteries will be supplied free of charge to replace defective components.
- ▶ Protec Micro, PTECF7 Fire Rated Downlights, Serenus and the Opus Sconce are provided with a five year replacement luminaire only warranty. Protec FR Fire Rated Downlights are provided with a 2 year replacement luminaire only warranty.
- ▶ Controls systems such as standalone sensors, switches, marshalling boxes and cabling are provided with a one year warranty for both parts and labour. DALI control systems are provided with a two year warranty for both parts and labour.
- ▶ LEDextra ranges are supplied with a three year parts or replacement luminaire only warranty with the exception of the IMPR RGBW, the Runway RGBW, the MOD RGBW, Tanek RGBW and the DexRing. These five ranges are supplied with our standard five year warranty during which defects within the first three years will be repaired on site and the warranty includes both parts and labour. For the final two years free of charge replacement components only will be supplied to rectify any failures but labour and other associated costs are not included.
- ▶ LEDEX ranges are supplied with a three year replacement luminaire only warranty.
- ▶ The Decorative Pendant ranges, Bebo, Dene, Nova, Fino and Stix are supplied with a 3 year replacement luminaire only warranty.

All warranties are subject to correct use of the product and will be invalidated by misuse, for example incorrect installation, unsuitable environmental conditions or incorrect maintenance. It is the duty of the customer to ensure that all the fault lies with the luminaire prior to requesting replacement parts or site repairs. In the event that no defect is found with the product our costs for attending site will be recharged to the customer and credit

will not be issued against returned products. No consequential losses incurred resulting from any defect with our product will be reimbursed.

Given the nature of LED technology a small percentage of LEDs may fail during the lifetime of a luminaire, this does not cause a reduction in lumen output. As such LED luminaires are only deemed to be faulty for warranty purposes when in excess of ten percent of LEDs have failed in a single luminaire.

On site repair of products under warranty will be undertaken during normal working hours, 9am to 5pm Monday to Friday, and will require unrestricted access to luminaires. Where required Dextra will provide access equipment to carry out repairs at height, should luminaires have been installed in locations where reasonable provision for maintenance access has not been made we reserve the right to supply replacement product only. On site warranty repairs will only be undertaken on the mainland of the UK and Ireland, in all other locations replacement product only will be provided.

If you require any assistance with regards to our products please contact our Customer Services department on 01747 858100.

ORDER CODES

LUMINAIRE

Code	Description	Power
TWS IP65 L7 NM3 LA3RC	Twin Spot, IP65, 760lm, Non-Maintained, Reacta-Control Emergency 3 Hour	3.0W
TWS IP65 L7 NM3 LSTR	Twin Spot, IP65, 760lm, Non-Maintained, Reacta-Link Emergency 3 Hour	3.0W
TWS IP65 L7 NM3 LA3D	Twin Spot, IP65, 760lm, Non-Maintained, DexNET Emergency 3 Hour	3.0W

All products are supplied with a 5 year battery warranty

MISCELLANEOUS

Code	Description
LSF	Low Smoke Zero Halogen

TWS IP65 L7 Installation

220-240V / 50-60Hz
IP65 IK08

Terminal Labelling:	
Power	
L1	Switched Live
E	Earth
N	Neutral
Emergency	
L2	Unswitched Live
DA/AT3	DALI Autotest
DA/AT3	DALI Autotest
Dimming	
-/D1/DA	Analogue/DSI/DALI
+/D2/DA	Analogue/DSI/DALI
L3	Switch Dim / Corridor Function

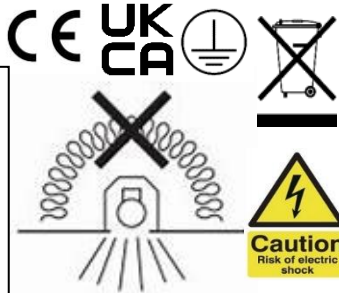

WARNING: Luminaire must be earthed. Risk of electric shock from LED boards if operated with cover removed. Installation / operation outside of luminaires intended scope invalidates warranty. Suitable only for domestic / light industrial / industrial applications within the scope of EN55015. Tested to compliance with BSEN 60598: specification for general requirements and tests. Must be installed by a suitably qualified person in accordance with all relevant legislation. Ambient operating temperature of 0°C to 25°C. If maximum operating temperature is exceeded luminaire will automatically dim / switch off. Terminal blocks are rated to 16A unless stated otherwise. The light source contained in this luminaire shall only be replaced by the manufacturer or his service agent or a similar qualified person. **LUMINAIRES WITH EMERGENCY PACK:** When supply is isolated battery output terminals may be live if battery is connected. Isolate mains and battery before servicing. Emergency luminaires require unswitched live connection taken from same phase as switched supply. When unswitched supply is connected status indicator illuminates green, when unswitched supply is disconnected indicator extinguishes and luminaire operates in emergency mode. 24 hour charge period required before undertaking full discharge test. Emergency test sheets provided should be used to record all emergency tests. Batteries should be replaced when 3 hour duration is not met. Excessive switching of permanent live may result in premature battery failure. Battery electrolyte can be harmful to eyes / open wounds, do not puncture, if electrolyte touches skin / eyes flush with water. Do not incinerate batteries.

<p>1.</p> <p>Remove the front cover by loosening the four screws.</p> <p>Disconnect LED when removing cover.</p>	<p>2.</p> <p>If required to remove gear tray, make sure to disconnect lamp head using plug and socket.</p> <p>Drill out the four fixing points on the back face. Ensure the fixings are adequately sealed in order to maintain the IP65 rating. Secure the luminaire with four screws.</p>
<p>3.</p> <p>Drill the cable entry point on the side wall. Ensure the provided cable gland is fitted, to maintain the IP65 rating.</p>	<p>4.</p> <p>Pass the cable through the cable gland, and wire directly into the terminal block. Secure the mains cable using the internal cable clamp.</p>
<p>5.</p> <p>Refit the cover to the body, and secure in place using the four screws.</p>	<p>6.</p> <p>Rotate the heads to the desired position by loosening the screws accordingly. Be sure to tighten the screws once positioned, to hold them in place.</p>

TWS IP65 L7 Installation

7.

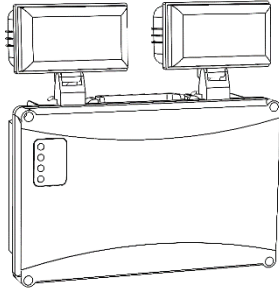

Do **NOT** cover the luminaire in any way and provide sufficient ventilation.

Installation is now complete.

Maintenance

- ① Disconnect luminaire before undertaking any maintenance or cleaning.
- ② Cleaning should be undertaken on external parts of the luminaire only using a slightly damp lint free cloth.
- ③ To access fitting use a pan pozi screwdriver to remove x4 screws from front cover.
- ④ Using a pan pozi screwdriver remove x2 screws to remove gear tray.
- ⑤ Please contact Dextra for assistance with spare component supply.

