



PRODUCT SPECIFICATION

TANEK CORNICE



INTRODUCTION

Offering up to 140 luminaire lumens per watt the Tanek Cornice combines efficiency with a robust design ideally suited to areas where there is a high risk of vandalism. Designed with a 1.2mm steel housing with a salt spray tested all weather paint finish and polycarbonate diffuser the Tanek Cornice can withstand extreme physical attack with an IK10 rating whilst ensuring long service in the field. All Tanek luminaires are supplied with tamper resistant diffuser fixings to further minimise the risk of vandalism and are supplied with our 5 year warranty to ensure peace of mind.

The Tanek Cornice has been designed to provide flexibility without compromising strength, offering 600mm, 1200mm and 1500mm housings, white or black bodies, with optional integral lithium emergency and all common dimming variants. We offer a range of wireless control systems providing localised grouping and control as well as comprehensive wireless systems allowing both standard and emergency luminaires to be centrally monitored.



CE IP65 IK10 TM21: L90>60K HOURS / L80>100K HOURS 3 STEP MACADAM ELLIPSE

APPLICATION

- Exterior
- Healthcare / Social Housing
- Industrial / Manufacturing
- Parking / Exterior
- Transport

SPECIFICATION

CONSTRUCTION

- Housing: 1.2mm CR4 steel
- Finish: Epoxy primer, RAL 9003 leatherette white, salt spray tested
- Finish: Epoxy primer, RAL 9005 leatherette black, salt spray tested
- Diffuser: Injection moulded high transmission opal polycarbonate
- IK10
- IP65

PERFORMANCE

- Part L2 compliant
- 3SDCM Three step Macadams ellipse
- TM21: L90>60K Hours / L80>100K Hours
- Up to 146 luminaire lumens per circuit Watt.

ENVIRONMENTAL

- Designed to allow simple replacement of components with commonly available tools in compliance with the Eco Design Directive, please see the installation leaflet for maintenance instructions.
- All critical components are mounted on a single tray for simple end of life repair or upgrade.
- Powered by European branded drivers and emergency modules ensuring replacement parts are easily sourced.
- Every luminaire is labelled with a unique ID number allowing easy identification of spare parts for the lifetime of the product.
- Contains no single use plastics or polystyrene packaging.
- Supplied in plain card boxes with paper tape ensuring packaging is easily recycled.
- Designed to allow simple disassembly for end of life recycling.
- UK based manufacturing providing local support throughout the product lifetime and minimising transportation miles.

EMERGENCY

- Available with optional standard, self test and autotest integral emergency with lithium batteries for extended

warranty and lifetime.

- Optional Reacta-Link wireless emergency for automated centralised reporting.
- Optional Reacta-Control wireless emergency for automated centralised reporting.
- Optional central battery changeover relay

CONTROL

- Optional compatibility with a range of dimming systems including DALI, DSI and Switch Dimming
- Optional White tunable
- Optional integral Reacta-Link for integration with Reacta-Link wireless installations
- Optional integral Reacta-Control for integration with Reacta-Control wireless installations

INSTALLATION

- Suitable for conduit installation
- Suitable for external surface installation

VARIATIONS

- Available with a wide range of colour temperatures and renderings
- Available in a range of housing sizes and lumen outputs
- Available in white or black finishes

IMAGES

PRODUCT IMAGES

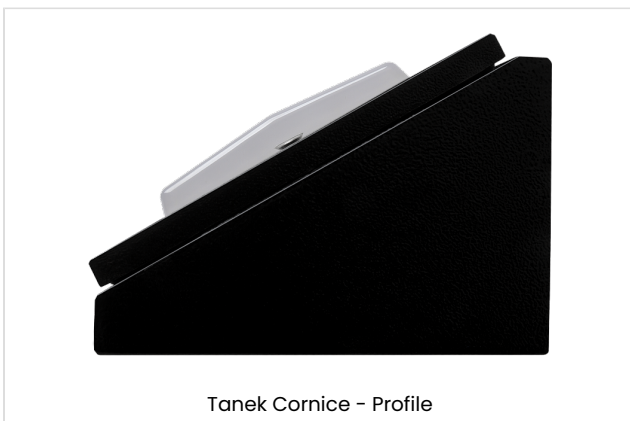

PROJECT IMAGES



Victoria Pier using the Tanek Cornice in black.



Victoria Pier using the Tanek Cornice in black.



Victoria Pier using the Tanek Cornice in black.



Victoria Pier using the Tanek Cornice in black.

TECHNICAL

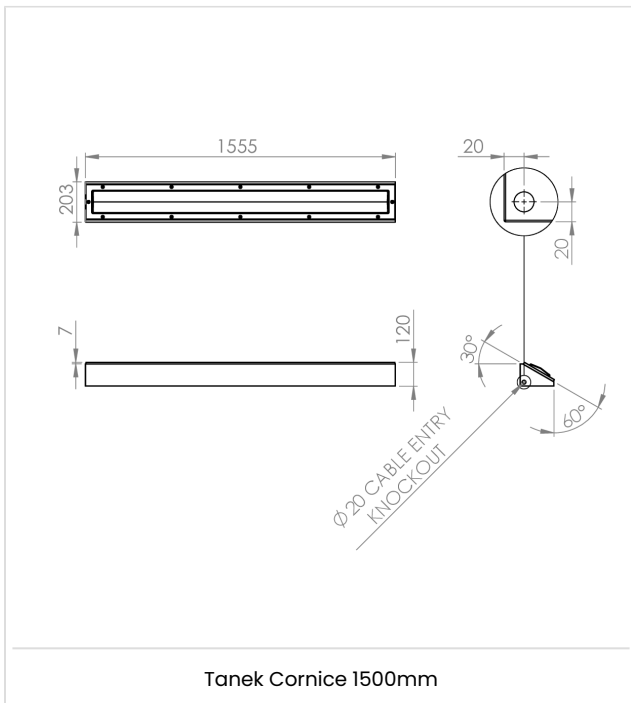
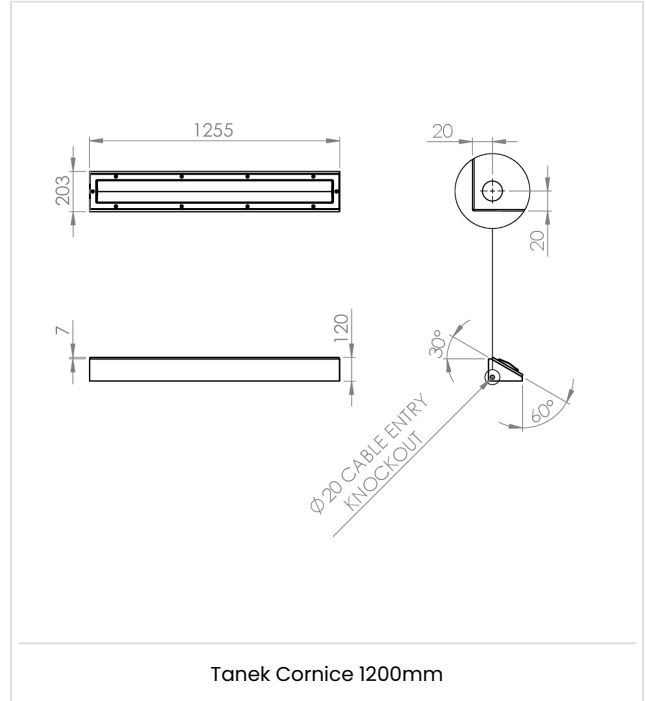
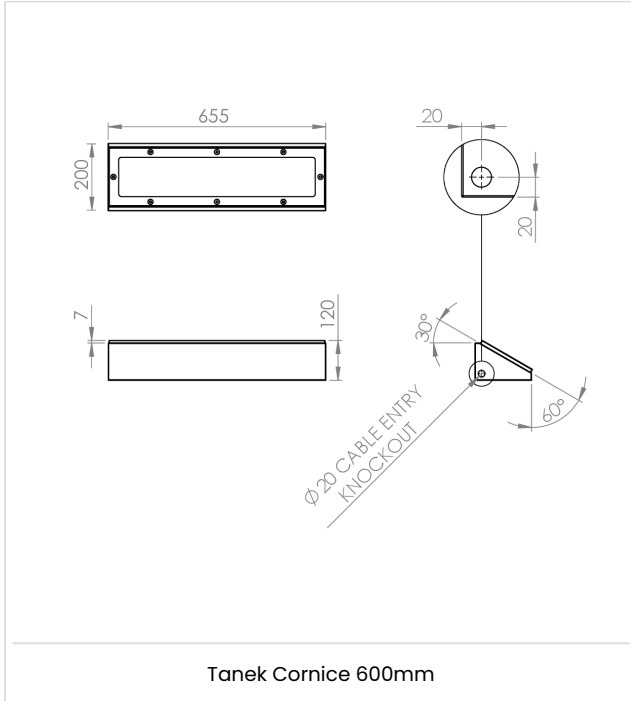

WARRANTY

At Dextra our commitment to service has been at the forefront throughout our history spanning more than forty years in the UK lighting market. Our service ethos extends beyond design and delivery, we believe supporting your installation throughout the warranty period is equally crucial, whilst the strength and longevity of Dextra Group provides peace of mind that our warranty will be supported throughout.

The Dextra range is supplied with a five year warranty commencing from the date of delivery. During the first three years defects will be repaired on site and the warranty will include both parts and labour. For the final two years drivers, emergency modules, wireless modules, sensors and LED circuits will be supplied free of charge to replace defective components, labour and other associated costs are not included.

Certain ranges and components are subject to exemptions:

- ▶ Lithium batteries are provided with a five year warranty. During the first three years defects will be repaired on site and the warranty will include both parts and labour. For the final two years replacement batteries will be supplied free of charge to replace defective components. Five year warranty became effective as of 03/02/25, Lithium emergency luminaires supplied prior to this date are supported with a three year on site warranty only. Labour and other associated costs are not included. Nickel Metal Hydride and Nickel Cadmium batteries are provided with a one year warranty for parts and labour.
- ▶ Emergency luminaires including AME2, EXI LED, EXI3, HBE3, HBE4, OAT2 LED and Twinspot are supplied with a one year warranty for parts and labour. Lithium variants suffixed with the 5YR part code, the Autotest emergency with the LA3 part code and wireless variants with LA3RC or LSTR part codes are supplied with a five year warranty. For these extended warranty variants for the first three years defects will be repaired on site and the warranty will include both parts and labour. For the final two years replacement batteries will be supplied free of charge to replace defective components.
- ▶ Protec Micro, PTECF7 Fire Rated Downlights, Serenus and the Opus Sconce are provided with a five year replacement luminaire only warranty. Protec FR Fire Rated Downlights are provided with a 2 year replacement luminaire only warranty.
- ▶ Controls systems such as standalone sensors, switches, marshalling boxes and cabling are provided with a one year warranty for both parts and labour. DALI control systems are provided with a two year warranty for both parts and labour.
- ▶ LEDextra ranges are supplied with a three year parts or replacement luminaire only warranty with the exception of the IMPR RGBW, the Runway RBGW, the MOD RGBW, Tanek RGBW and the DexRing. These five ranges are supplied with our standard five year warranty during which defects within the first three years will be repaired on site and the warranty includes both parts and labour. For the final two years free of charge replacement components only will be supplied to rectify any failures but labour and other associated costs are not included.
- ▶ LEDEX ranges are supplied with a three year replacement luminaire only warranty.
- ▶ The Decorative Pendant ranges, Bebo, Dene, Nova, Fino and Stix are supplied with a 3 year replacement luminaire only warranty.

All warranties are subject to correct use of the product and will be invalidated by misuse, for example incorrect installation, unsuitable environmental conditions or incorrect maintenance. It is the duty of the customer to ensure that all the fault lies with the luminaire prior to requesting replacement parts or site repairs. In the event that no defect is found with the product our costs for attending site will be recharged to the customer and credit

will not be issued against returned products. No consequential losses incurred resulting from any defect with our product will be reimbursed.

Given the nature of LED technology a small percentage of LEDs may fail during the lifetime of a luminaire, this does not cause a reduction in lumen output. As such LED luminaires are only deemed to be faulty for warranty purposes when in excess of ten percent of LEDs have failed in a single luminaire.

On site repair of products under warranty will be undertaken during normal working hours, 9am to 5pm Monday to Friday, and will require unrestricted access to luminaires. Where required Dextra will provide access equipment to carry out repairs at height, should luminaires have been installed in locations where reasonable provision for maintenance access has not been made we reserve the right to supply replacement product only. On site warranty repairs will only be undertaken on the mainland of the UK and Ireland, in all other locations replacement product only will be provided.

If you require any assistance with regards to our products please contact our Customer Services department on 01747 858100.

ORDER CODES

LUMINAIRE

Code	Description	Power	Llm/W
TK2C L16	Tanek, 1,204llm, Cornice, 600mm, Opal, Colour 84	10.9W	110
TK2C L22	Tanek, 1,655llm, Cornice, 600mm, Opal, Colour 84	14.8W	112
TK2C L26	Tanek, 1,956llm, Cornice, 1200mm, Opal, Colour 84	16.1W	121
TK2C L44	Tanek, 3,331llm, Cornice, 1200mm, Opal, Colour 84	26.7W	125
TK2C L35	Tanek, 2,634llm, Cornice, 1500mm, Opal, Colour 84	20.0W	131
TK2C L45	Tanek, 3,383llm, Cornice, 1500mm, Opal, Colour 84	23.2W	146
TK2C L54	Tanek, 4,063llm, Cornice, 1500mm, Opal, Colour 84	29.1W	140
TK2C L63	Tanek, 4,741llm, Cornice, 1500mm, Opal, Colour 84	34.6W	137
TK2C L80	Tanek, 6,018llm, Cornice, 1500mm, Opal, Colour 84.	42.1W	143
TK2C L96	Tanek, 7,224llm, Cornice, 1500mm, Opal, Colour 84.	51.3W	141

DIMMING

Code	Description
A	DALI Digital Addressable Lighting Interface
S	Switch Dimming
D	DSI Digital Dimming
C	Bi-Level Dimming For Standalone Switched Sensor

CONTROL

Code	Description
DN	DexNET Node, Wireless Node only.
R25E	Reacta 25, Presence & Bright Out, On / Off, 2.5-4M
R25C*	Reacta 25, Presence & Bright Out, Bi-Level Dimming, 2.5-4M
RLI	Reacta-Link, Wireless Enabled Luminaire
RLM	Reacta-Link, Wireless, Presence & Bright Out, 2.5-4M
RC	Reacta-Control, Wireless Enabled Luminaire
RCMC*	Reacta-Control, Presence & Bright Out, Bi-level Dimming, 2.5-4M
RCME	Reacta-Control, Presence & Bright Out, On / Off, 2.5-4M

Please click [here](#) for full details on our wireless controls.

*Bi-Level Dimming will only dim the luminaire to 10% during absence and brightout, it will not turn the luminaire off.

EMERGENCY

Code	Description
LE3	Lithium Standard Emergency 3 Hour
LS3	Lithium Selftest Emergency 3 Hour
LA3	Lithium Autotest Emergency 3 Hour
LA3D	Lithium DexNET Emergency 3 Hour
LSTR	Lithium Reacta-Link Emergency 3 Hour
LA3RC	Lithium Reacta-Control Emergency 3 Hour
CB	Central Battery, Please Specify 110V or 230V when Ordering

MISCELLANEOUS

Code	Description
C**	Select Colour Temperature and Rendering; C827, C83, C85, C865, C93, C94
WH	White Finish
BL	Black Finish

LSF

Low Smoke Zero Halogen

220-240V / 50-60Hz

IP65

IK10



WARNING: Luminaire must be earthed. Risk of electric shock from LED boards if operated with cover removed. Installation / operation outside of luminaires intended scope invalidates warranty. Suitable only for domestic / light industrial / industrial applications within the scope of EN55015. Tested to compliance with BSEN 60598: specification for general requirements and tests. Must be installed by a suitably qualified person in accordance with all relevant legislation. Ambient operating temperature of 0°C to 25°C. If maximum operating temperature is exceeded luminaire will automatically dim / switch off. Terminal blocks are rated to 16A unless stated otherwise. The light source contained in this luminaire shall only be replaced by the manufacturer or his service agent or a similar qualified person. **LUMINAIRES WITH EMERGENCY PACK:** When supply is isolated battery output terminals may be live if battery is connected. Isolate mains and battery before servicing. Emergency luminaires require unswitched live connection taken from same phase as switched supply. When unswitched supply is connected status indicator illuminates green, when unswitched supply is disconnected indicator extinguishes and luminaire operates in emergency mode. 24 hour charge period required before undertaking full discharge test. Emergency test sheets provided should be used to record all emergency tests. Batteries should be replaced when 3 hour duration is not met. Excessive switching of permanent live may result in premature battery failure. Battery electrolyte can be harmful to eyes / open wounds, do not puncture, if electrolyte touches skin / eyes flush with water. Do not incinerate batteries.

Terminal Labelling:	
Power	
L1	Switched Live
E	Earth
N	Neutral
Emergency	
L2	Unswitched Live
DA/AT3	DALI Autotest
DA/AT3	DALI Autotest
Dimming	
-D1/DA	Analogue/DSI/DALI
+D2/DA	Analogue/DSI/DALI
L3	Switch Dim / Corridor Function

1.

10 x

Unpack the luminaire and undo the 10 x M5 6 Lobe Pin Drive screws securing the frame. Remove the frame and proceed to hang it on the tethers.

2.

Remove the screw holding the gear tray in place. (1) Push the tray to one side. (2) Lift and tilt the gear tray to remove.

3.

Knockout the semi-shear from the housing if bringing the cable in through the side.

4.

Cornice and slim only - Drill 20mm cable hole in desired location. Drill the rear of the housing if a central cable entry is required instead.

5.

Slim version only - Drill alternate cable entry hole position if chosen grommet depth will clash with nutsert.

6.

Drill suitable fixings to suit required installation. **Please note, it is the contractor's responsibility to ensure the holes are suitably sealed. Failure to do so will invalidate the luminaire's IP rating.**

Tanek Installation

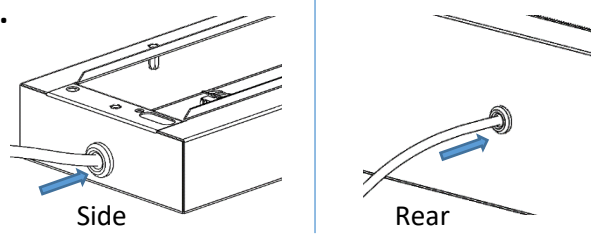
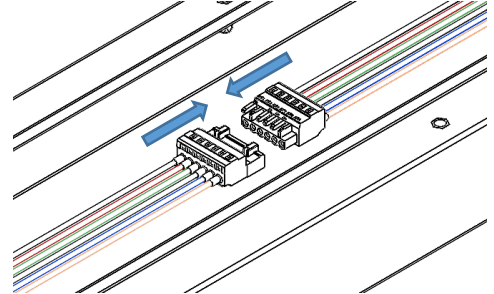
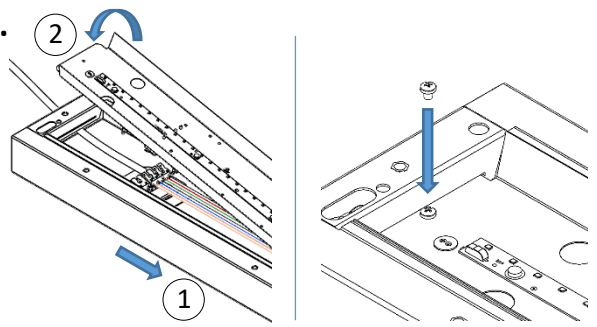
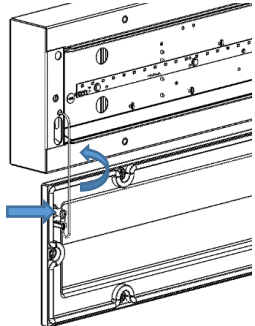
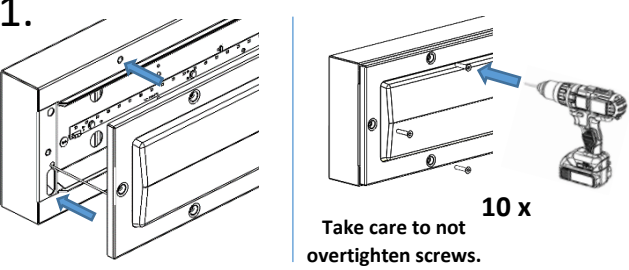
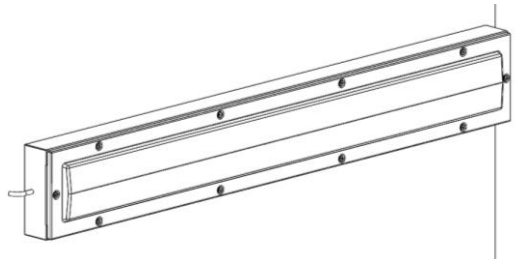
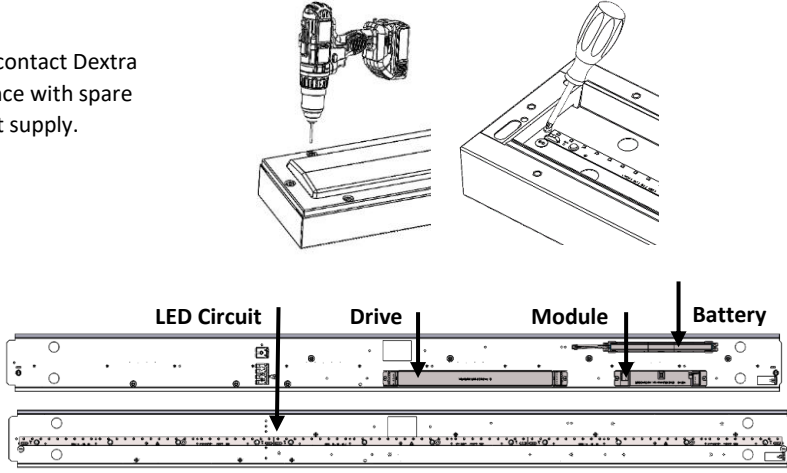
<p>7.</p>  <p>Side</p> <p>Rear</p> <p>Feed flex through preferred cable entry (contractor to supply suitable grommet). Make relevant electrical connection (all fittings will have 6 pole terminals due to generic housing to tray connector loom).</p>	<p>8.</p>  <p>Connect the tray to the housing using the internal loom.</p>
<p>9.</p>  <p>(1) Slide one end of the gear tray into the housing. (2) Then lower the gear tray into place. Secure the tray with the screw that was removed earlier in step 2.</p>	<p>10.</p>  <p>Offer the frame up to the housing. Ensure screw boss on diffuse will align with clearance hole in housing</p>
<p>11.</p>  <p>Take care to not overtighten screws.</p> <p>10 x</p> <p>Rest the frame on top of the housing. Insert all M5 screws before fully tightening to ensure alignment.</p>	<p>12.</p>  <p>Installation is now complete.</p>
<p>Maintenance</p> <ol style="list-style-type: none"> 1. Disconnect luminaire before undertaking any maintenance or cleaning. 2. Cleaning should be undertaken on external parts of the luminaire only using a slightly damp lint free cloth. 3. To access fitting remove the M5 Lobe Pin Drive Screws. Frame and diffuser can now be removed. 4. To remove gear tray and components use a pan pozi screwdriver. 5. Please contact Dextra for assistance with spare component supply. 6. Please contact Dextra for assistance with spare component supply.  <p>LED Circuit</p> <p>Drive</p> <p>Module</p> <p>Battery</p>	