



Product Specification

RUBIX OPAL



INTRODUCTION

The Rubix Opal combines the benefits of a traditional homogeneously lit diffuser with an embedded cellular optic, this unique pairing allows us to offer a visually comfortable low glare diffuser with the efficiency of a modern optic design.

The Rubix Opal combines these benefits without compromising versatility and is available in a wide range of variants including 600x600 and 1200x600 sizes suitable for lay in, pull up and plasterboard installations. All variants come in a selection of lumen outputs, optional compatibility with most common dimming systems and integral sensor variants ensuring that energy savings can be maximised. The Rubix Opal is also available with integral lithium emergency offering extended lifetime and warranty compared to traditional battery chemistries reducing life time cost and ongoing maintenance as well as a wide range of wireless control systems providing localised grouping and control allowing both standard and emergency luminaires to be centrally monitored.

UK
CA CE IP20 TM21: L90>60K HOURS / L80>100K HOURS 3 STEP MACADAM ELLIPSE

APPLICATION

- Commercial / Offices
- Education

SPECIFICATION

CONSTRUCTION

- Housing: 0.7mm CR4 steel
- Finish: Polyester powder painted RAL 9016 textura matt white
- Finish: Polyester powder painted RAL 9006 textura matt grey
- Finish: Polyester powder painted RAL 9005 textura matt black
- Diffuser: 2mm high transmission opal polycarbonate TP(a) rated
- Diffuser: Injection moulded high transmission opal polycarbonate cell with miro silver aluminium inserts and injection moulded clip on bezel
- IP20

PERFORMANCE

- Part L2 compliant
- BSEN 12464-1:2011 3000 Candela 65° and UGR 19 compliance
- 3SDCM Three step Macadams ellipse
- TM21: L90>60K Hours / L80>100K Hours
- Up to 165 luminaire lumens per circuit Watt.

ENVIRONMENTAL

- Designed to allow simple replacement of components with commonly available tools in compliance with the Eco Design Directive, please see the installation leaflet for maintenance instructions.
- Powered by European branded drivers and emergency modules ensuring replacement parts are easily sourced.
- Every luminaire is labelled with a unique ID number allowing easy identification of spare parts for the lifetime of the product.
- Contains no single use plastics or polystyrene packaging.
- Supplied in plain card boxes with paper tape ensuring packaging is easily recycled.
- Designed to allow simple disassembly for end of life recycling.
- UK based manufacturing providing local support throughout the product lifetime and minimising transportation miles.

EMERGENCY

- Available with optional standard, self test and autotest integral emergency with lithium batteries for extended warranty and lifetime.
- Optional Reacta-Link wireless emergency for automated centralised reporting.

- Optional Reacta-Control wireless emergency for automated centralised reporting.
- Optional central battery changeover relay

CONTROL

- HFR 1-10V analogue dimming
- Optional compatibility with a range of dimming systems including DALI, DSI and Switch Dimming
- Optional Integral R44 presence and daylight sensor
- Optional Integral Reacta-Air wireless presence and daylight regulations sensor
- Optional integral Reacta-Link for integration with Reacta-Link wireless installations
- Optional integral Reacta-Control for integration with Reacta-Control wireless installations

INSTALLATION

- Suitable for lay-in installation in exposed T ceilings
- Suitable for pull-up installation in concealed grid ceilings
- Suitable for plasterboard installation when purchased with the appropriate plasterboard kit
- Alugrid 08 and 16 compatible options available. Please see miscellaneous ordering codes.

VARIATIONS

- Available with a wide range of colour temperatures and renderings
- Available in a range of housing sizes and lumen outputs

IMAGES

PRODUCT IMAGES



PROJECT IMAGES

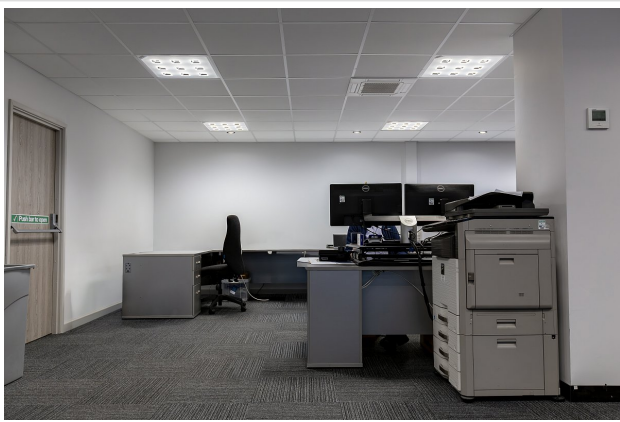

An office using the Rubix Opal

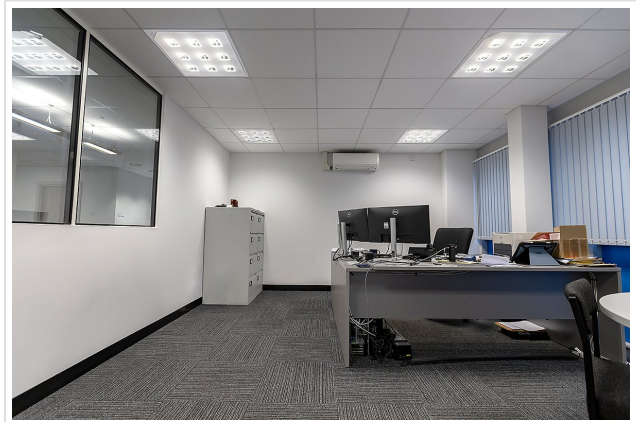

An office using the Rubix Opal

TECHNICAL

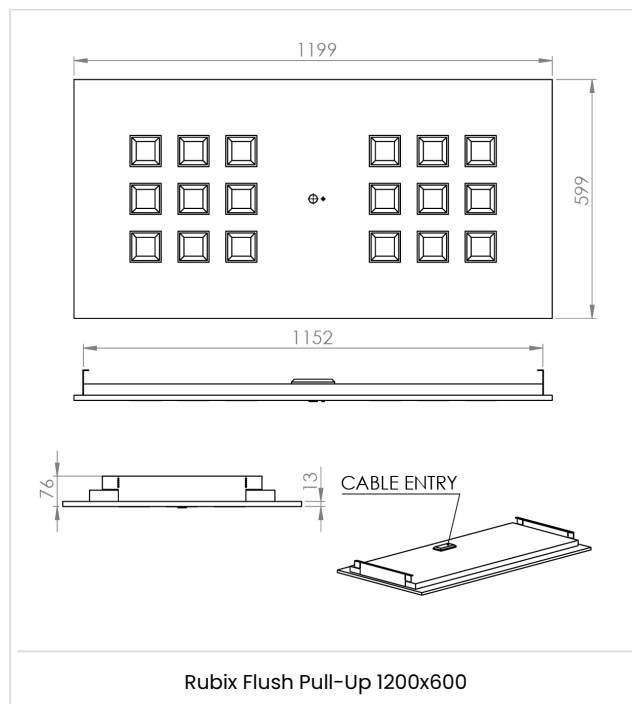
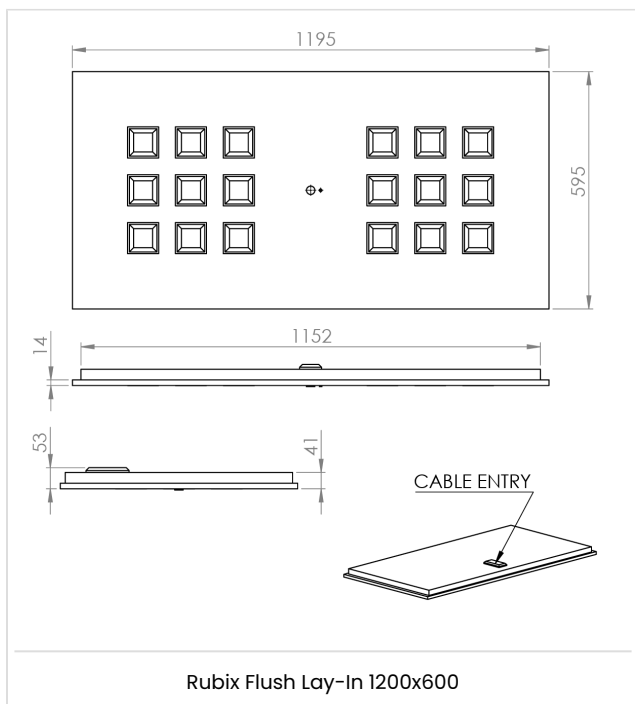
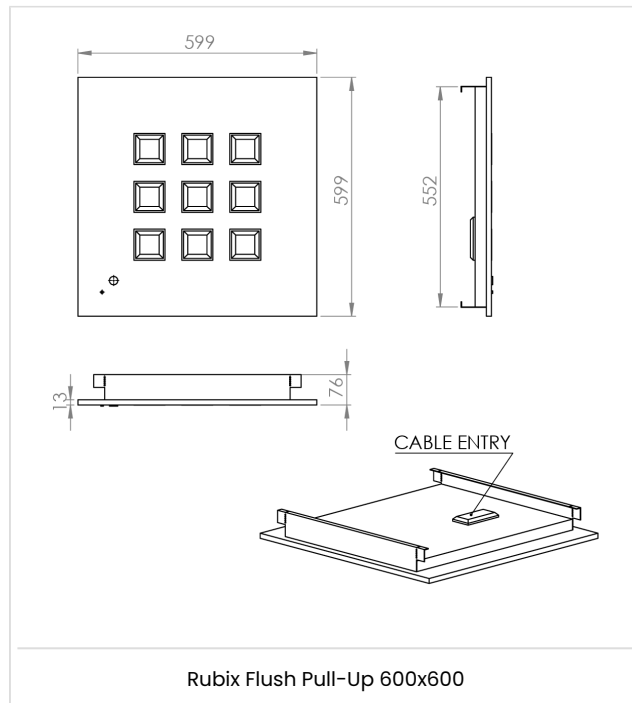
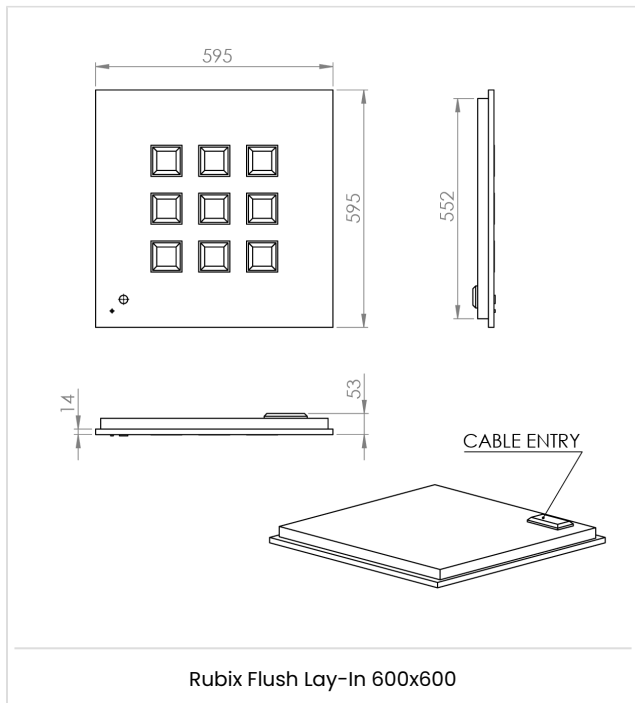

WARRANTY

At Dextra our commitment to service has been at the forefront throughout our history spanning more than forty years in the UK lighting market. Our service ethos extends beyond design and delivery, we believe supporting your installation throughout the warranty period is equally crucial, whilst the strength and longevity of Dextra Group provides peace of mind that our warranty will be supported throughout.

The Dextra range is supplied with a five year warranty commencing from the date of delivery. During the first three years defects will be repaired on site and the warranty will include both parts and labour. For the final two years drivers, emergency modules, wireless modules, sensors and LED circuits will be supplied free of charge to replace defective components, labour and other associated costs are not included.

Certain ranges and components are subject to exemptions:

- ▶ Lithium batteries are provided with a five year warranty. During the first three years defects will be repaired on site and the warranty will include both parts and labour. For the final two years replacement batteries will be supplied free of charge to replace defective components. Five year warranty became effective as of 03/02/25, Lithium emergency luminaires supplied prior to this date are supported with a three year on site warranty only. Labour and other associated costs are not included. Nickel Metal Hydride and Nickel Cadmium batteries are provided with a one year warranty for parts and labour.
- ▶ Emergency luminaires including AME2, EXI LED, EXI3, HBE3, HBE4, OAT2 LED and Twinspace are supplied with a one year warranty for parts and labour. Lithium variants suffixed with the 5YR part code, the Autotest emergency with the LA3 part code and wireless variants with LA3RC or LSTR part codes are supplied with a five year warranty. For these extended warranty variants for the first three years defects will be repaired on site and the warranty will include both parts and labour. For the final two years replacement batteries will be supplied free of charge to replace defective components.
- ▶ Protec Micro, PTECF7 Fire Rated Downlights, Serenus and the Opus Sconce are provided with a five year replacement luminaire only warranty. Protec FR Fire Rated Downlights are provided with a 2 year replacement luminaire only warranty.
- ▶ Controls systems such as standalone sensors, switches, marshalling boxes and cabling are provided with a one year warranty for both parts and labour. DALI control systems are provided with a two year warranty for both parts and labour.
- ▶ LEDextra ranges are supplied with a three year parts or replacement luminaire only warranty with the exception of the IMPR RGBW, the Runway RGBW, the MOD RGBW, Tanek RGBW and the DexRing. These five ranges are supplied with our standard five year warranty during which defects within the first three years will be repaired on site and the warranty includes both parts and labour. For the final two years free of charge replacement components only will be supplied to rectify any failures but labour and other associated costs are not included.
- ▶ LEDEX ranges are supplied with a three year replacement luminaire only warranty.
- ▶ The Decorative Pendant ranges, Bebo, Dene, Nova, Fino and Stix are supplied with a 3 year replacement luminaire only warranty.

All warranties are subject to correct use of the product and will be invalidated by misuse, for example incorrect installation, unsuitable environmental conditions or incorrect maintenance. It is the duty of the customer to ensure that all the fault lies with the luminaire prior to requesting replacement parts or site repairs. In the event that no defect is found with the product our costs for attending site will be recharged to the customer and credit

will not be issued against returned products. No consequential losses incurred resulting from any defect with our product will be reimbursed.

Given the nature of LED technology a small percentage of LEDs may fail during the lifetime of a luminaire, this does not cause a reduction in lumen output. As such LED luminaires are only deemed to be faulty for warranty purposes when in excess of ten percent of LEDs have failed in a single luminaire.

On site repair of products under warranty will be undertaken during normal working hours, 9am to 5pm Monday to Friday, and will require unrestricted access to luminaires. Where required Dextra will provide access equipment to carry out repairs at height, should luminaires have been installed in locations where reasonable provision for maintenance access has not been made we reserve the right to supply replacement product only. On site warranty repairs will only be undertaken on the mainland of the UK and Ireland, in all other locations replacement product only will be provided.

If you require any assistance with regards to our products please contact our Customer Services department on 01747 858100.

ORDER CODES

LUMINAIRE

Lay-In

Code	Description	Power	Llm/W
RBXRO L32	Rubix Opal Lay-In, 600x600, 2,673lm, Opal Cell, Colour 84.	17.7W	151
RBXRO L40	Rubix Opal Lay-In, 600x600, 3,348lm, Opal Cell, Colour 84.	27.0w	124
RBXRO L45	Rubix Opal Lay-In, 600x600, 3,762lm, Opal Cell, Colour 84.	25.4W	148
RBXRO 126 L64	Rubix Opal Lay-In, 1200x600, 5,346lm, Opal Cell, Colour 84.	32.4W	165
RBXRO 126 L80	Rubix Opal Lay-In, 1200x600, 6,696lm, Opal Cell, Colour 84.	40.8w	164
RBXRO 126 L90	Rubix Opal Lay-In, 1200x600, 7,524lm, Opal Cell, Colour 84.	45.9w	164

For AluGrid compatible versions please specify lay-in luminaire with correct ALU suffix shown in miscellaneous ordering codes

Pull-Up

Code	Description	Power	Llm/W
RBXPO L32	Rubix Opal Pull-Up, 600x600, 2,673lm, Opal Cell, Colour 84.	17.7w	151
RBXPO 126 L90	Rubix Opal Pull-Up, 1200x600, 7,524lm, Opal Cell, Colour 84.	45.9W	164
RBXPO 126 L80	Rubix Opal Pull-Up, 1200x600, 6,696lm, Opal Cell, Colour 84.	40.8w	164
RBXPO 126 L64	Rubix Opal Pull-Up, 1200x600, 5,346lm, Opal Cell, Colour 84.	32.4w	165
RBXPO L45	Rubix Opal Pull-Up, 600x600, 3,762lm, Opal Cell, Colour 84.	25.4w	148
RBXPO L40	Rubix Opal Pull-Up, 600x600, 3,348lm, Opal Cell, Colour 84.	27.0W	124

For plasterboard ceilings please specify lay-in luminaire and appropriate plasterboard kit.

DIMMING

Code	Description
A	DALI Digital Addressable Lighting Interface
S	Switch Dimming
D	DSI Digital Dimming
H	HFR Analogue 1-10v
C	Bi-Level Dimming For Standalone Switched Sensor

CONTROL

Code	Description
R44	Reacta 44, Presence & Daylight, 2.5-7M
D44	DexNET Sensor, Wireless, Presence & Daylight, 2.5-5M
DN	DexNET Node, Wireless Node only.
RAS	Reacta-Air Bluetooth, Wireless, Presence & Daylight, 2.5-3M
RLI	Reacta-Link, Wireless Enabled Luminaire
RLS	Reacta-Link Wireless, Presence & Daylight, 2.5M-5M
RC	Reacta-Control, Wireless Enabled Luminaire
RCS	Reacta-Control Wireless, Presence & Daylight, 2.5-4M

EMERGENCY

Code	Description
LE3	Lithium Standard Emergency 3 Hour
LS3	Lithium Selftest Emergency 3 Hour
LA3	Lithium Autotest Emergency 3 Hour
LA3D	Lithium DexNET Emergency 3 Hour

LSTR	Lithium Reacta-Link Emergency 3 Hour
LA3RC	Lithium Reacta-Control Emergency 3 Hour
CB	Central Battery, Please Specify 110V or 230V when Ordering

MISCELLANEOUS

Code	Description
C**	Select Colour Temperature and Rendering; C827, C83, C85, C865, C93, C94
ALU16	Alugrid 15/16 Ceiling Compatible
ALU08	Alugrid 15/08 Ceiling Compatible
LSF	Low Smoke Zero Halogen

Rubix Flush (Lay-In) Installation

220-240V / 50-60Hz
IP20

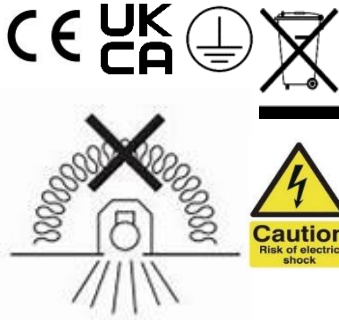

WARNING: Luminaire must be earthed. Risk of electric shock from LED boards if operated with cover removed. Installation / operation outside of luminaires intended scope invalidates warranty. Suitable only for domestic / light industrial / industrial applications within the scope of EN55015. Tested to compliance with BSEN 60598: specification for general requirements and tests. Must be installed by a suitably qualified person in accordance with all relevant legislation. Ambient operating temperature of 0°C to 25°C. If maximum operating temperature is exceeded luminaire will automatically dim / switch off. Terminal blocks are rated to 16A unless stated otherwise. The light source contained in this luminaire shall only be replaced by the manufacturer or his service agent or a similar qualified person. **LUMINAIRES WITH EMERGENCY PACK:** When supply is isolated battery output terminals may be live if battery is connected. Isolate mains and battery before servicing. Emergency luminaires require unswitched live connection taken from same phase as switched supply. When unswitched supply is connected status indicator illuminates green, when unswitched supply is disconnected indicator extinguishes and luminaire operates in emergency mode. 24 hour charge period required before undertaking full discharge test. Emergency test sheets provided should be used to record all emergency tests. Batteries should be replaced when 3 hour duration is not met. Excessive switching of permanent live may result in premature battery failure. Battery electrolyte can be harmful to eyes / open wounds, do not puncture, if electrolyte touches skin / eyes flush with water. Do not incinerate batteries.

Terminal Labelling:	
Power	
L / 1	Switched Live
E / ⚡	Earth
N	Neutral
Emergency	
L2 / 2	Unswitched Live
DA/AT3	DALI Autotest
DA/AT3	DALI Autotest
Dimming	
-D1/DA	Analogue/DSI/DALI
+D2/DA	Analogue/DSI/DALI
SD	Switch Dim / Corridor Function

1. RBXRFL (Lay-In)

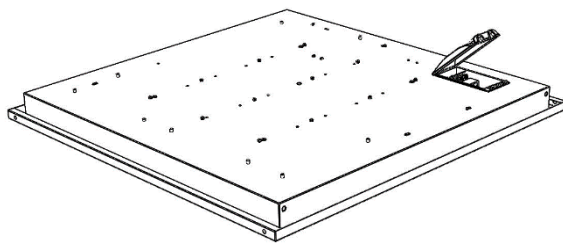

Fitting is supplied as one-piece unit.
595X595mm to rest on 15/24mm exposed T bar

2.

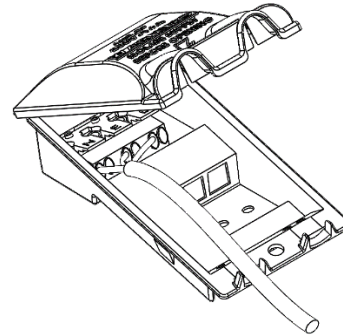

Electrical connection is made via integrated connection back-flap – allows for LEN L1 (emergency) and D1/D2 <or +/- for 1-10v> where specified.

3.

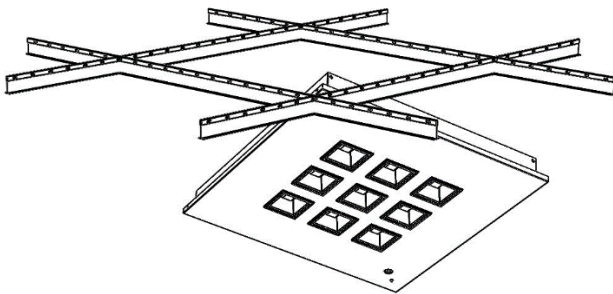

Carefully lift and tilt the luminaire into the ceiling aperture. Fitting will self-locate on grid

4.

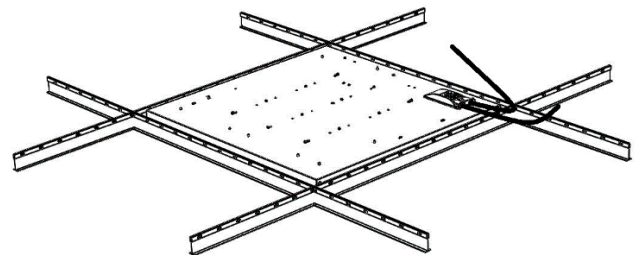

Fitting installed (shown here with loop-in / loop-out cables)

Maintenance

- ① Disconnect luminaire before undertaking any maintenance or cleaning.
- ② Cleaning should be undertaken on external parts of the luminaire only using a slightly damp lint free cloth.
- ③ To remove rear housing use a pan pozi screwdriver to remove screws.

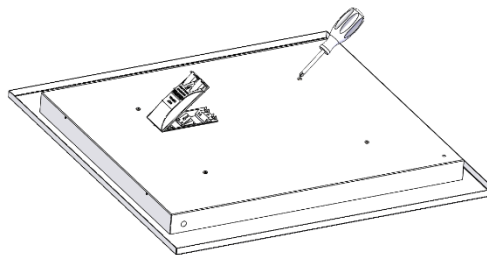

- ④ Use a pan pozi screwdriver when removing components.
- ⑤ Please contact Dextra for assistance with spare component supply.

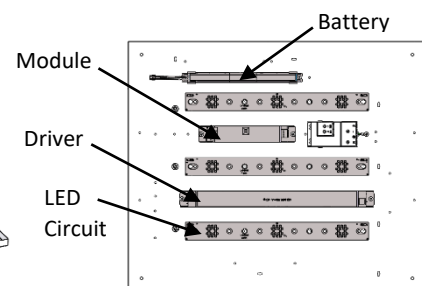

Rubix Flush (Pull-Up) Installation

220-240V / 50-60Hz
IP20



Terminal Labelling:

Power

L / 1 Switched Live
E / ⊕ Earth
N Neutral

Emergency

L2 / 2 Unswitched Live
DA/AT3 DALI Autotest
DA/AT3 DALI Autotest

Dimming

-D1/DA Analogue/DSI/DALI
+D2/DA Analogue/DSI/DALI
SD Switch Dim / Corridor Function



WARNING: Luminaire must be earthed. Risk of electric shock from LED boards if operated with cover removed. Installation / operation outside of luminaires intended scope invalidates warranty. Suitable only for domestic / light industrial / industrial applications within the scope of EN55015. Tested to compliance with BSEN 60598: specification for general requirements and tests. Must be installed by a suitably qualified person in accordance with all relevant legislation. Ambient operating temperature of 0°C to 25°C. If maximum operating temperature is exceeded luminaire will automatically dim / switch off. Terminal blocks are rated to 16A unless stated otherwise. The light source contained in this luminaire shall only be replaced by the manufacturer or his service agent or a similar qualified person. **LUMINAIRES WITH EMERGENCY PACK:** When supply is isolated battery output terminals may be live if battery is connected. Isolate mains and battery before servicing. Emergency luminaires require unswitched live connection taken from same phase as switched supply. When unswitched supply is connected status indicator illuminates green, when unswitched supply is disconnected indicator extinguishes and luminaire operates in emergency mode. 24 hour charge period required before undertaking full discharge test. Emergency test sheets provided should be used to record all emergency tests. Batteries should be replaced when 3 hour duration is not met. Excessive switching of permanent live may result in premature battery failure. Battery electrolyte can be harmful to eyes / open wounds, do not puncture, if electrolyte touches skin / eyes flush with water. Do not incinerate batteries.

1.

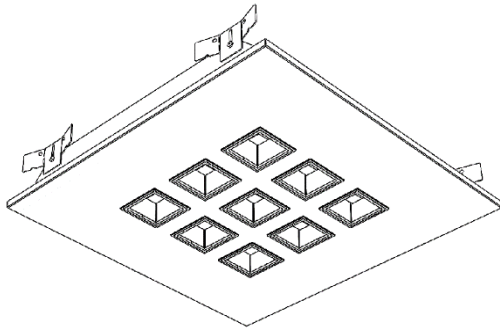

Fitting is supplied as a complete unit – with brackets already attached. Fitting measures 599x599mm – designed to pull-up (clamp) to various ceilings.

2.

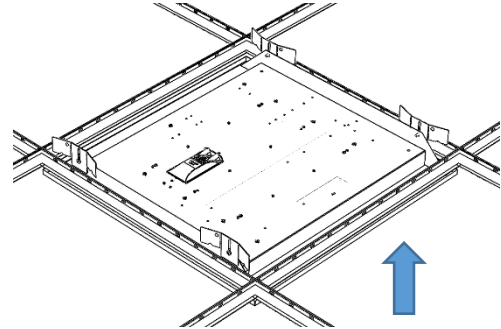

Regardless of ceiling type, the fixture should be offered up and into the aperture.

3.

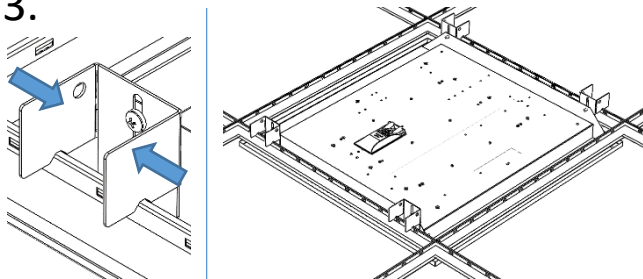

Then bend all of the brackets as shown – fixture will hang below ceiling.

4.

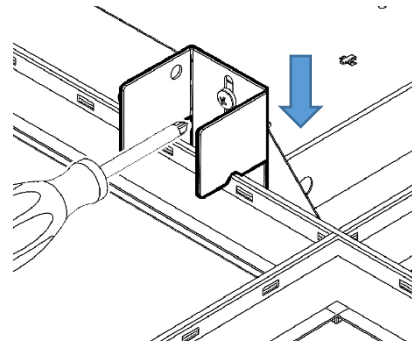

Each bracket should be adjusted, ensuring fixture is tight against grid/level with tiles where applicable - exposed T grid shown. Tighten screws on all brackets.

5.

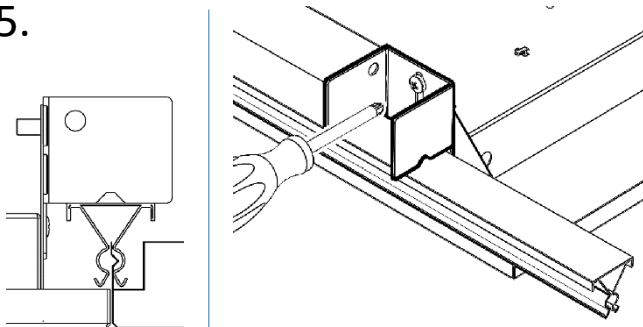

SAS 120 clip-in, fixture stops up against concealed T bar.

6.

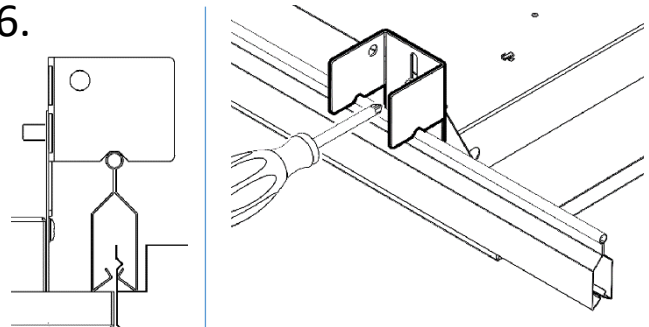

SAS 150 clip-in, fixture stops up against concealed T bar.

Rubix Flush (Pull-Up) Installation

7.

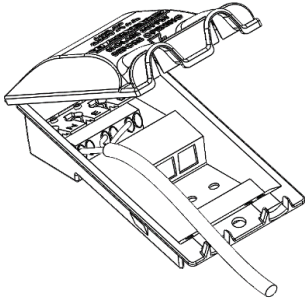

Electrical connection is made via integrated connection back-flap – allows for LEN L1 (emergency) and D1/D2 <or +/- for 1-10v> where specified.

8.

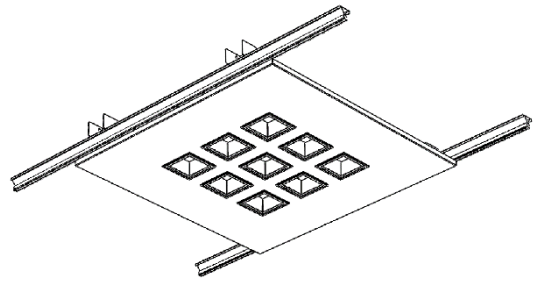

Installed fixture on SAS 120 grid.

Maintenance

① Disconnect luminaire before undertaking any maintenance or cleaning.

② Cleaning should be undertaken on external parts of the luminaire only using a slightly damp lint free cloth.

③ To remove rear housing use a pan pozi screwdriver to remove screws.

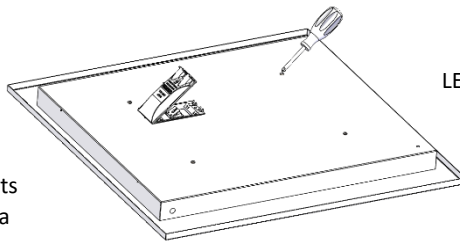

④ Use a pan pozi screwdriver when removing components.

⑤ Please contact Dextra for assistance with spare component supply.

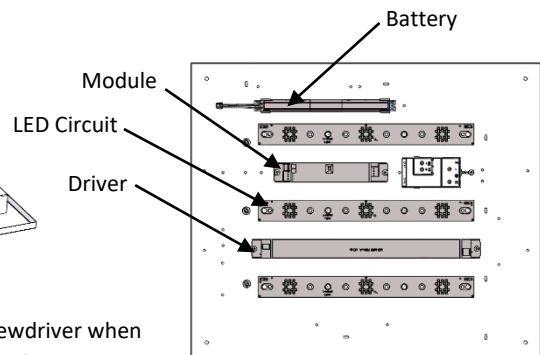

Plasterboard Kit Installation

IP20

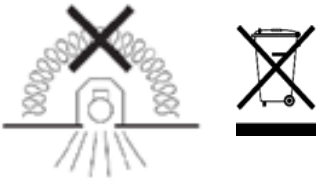

1. For use with lay-in luminaires

	Cut out sizes (mm)	O/A size
PBK 66	612x612	647x647
PBK 126	1212x612	1247x647
PBK 123	1212x312	1247x347

2.

Compatible fittings:

- Rubini Recessed Modular
- Rubix Recessed
- Rubix Flush
- MOD Office
- MOD Slim
- MOD UGR
- MOD Curve
- MOD Caelus
- Dual
- Dual Square
- Arcus Flush
- Arcus Duo
- Arcus Mono

3.

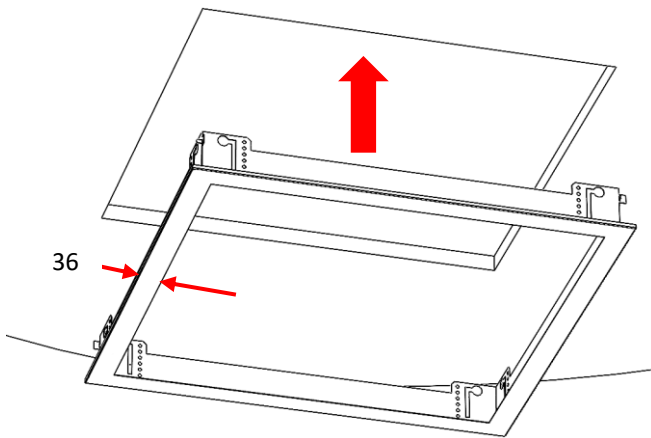

4.

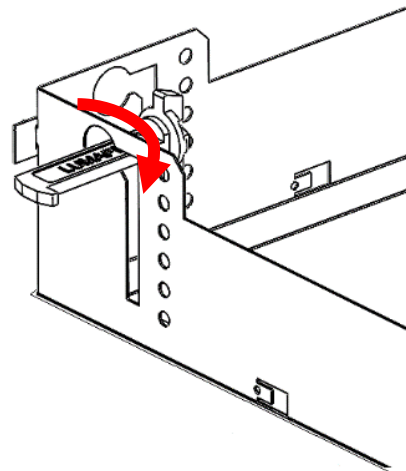

5.

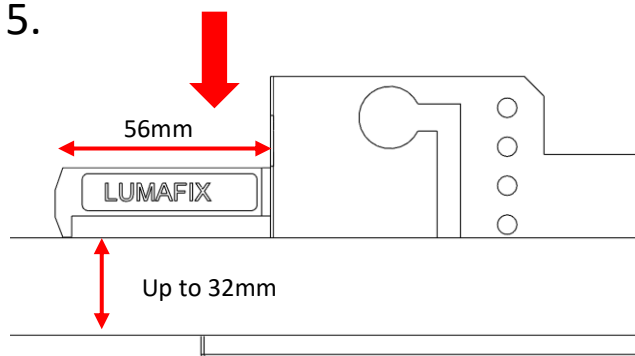

Ceilings with thickness up to 32mm

6.

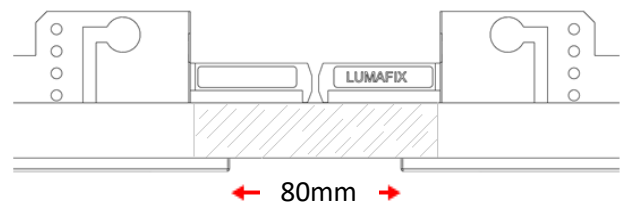

Note minimum distance between frames

7. Tighten Lumafix

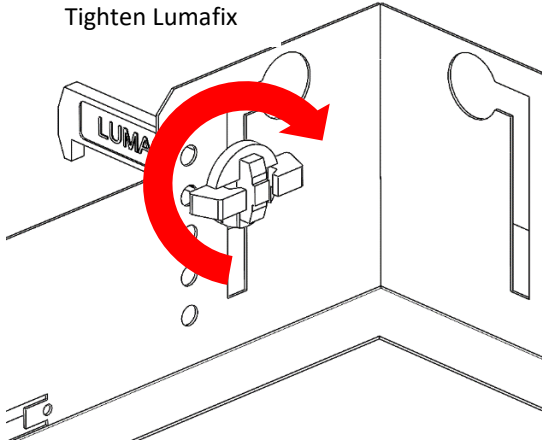

8.

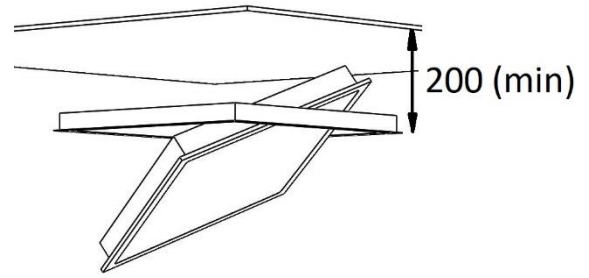

Luminaire is designed to simply lift and tilt in to aperture resting on back of plasterboard kit.
NOTE Minimum void to install.