



PRODUCT SPECIFICATION

RUBINI RECESSED 12



INTRODUCTION

Where lighting must be both discreet and attractive, the Rubini Recessed 12 provides the optimum solution with its small form factor combined with a modern and attractive cellular design. With excellent glare control as low as UGR 16 and cutting edge efficiency in excess of 145 luminaire lumens per watt, the Rubini Recessed 12 offers superb efficiency and architectural appeal. With a die cast aluminium housing, injection moulded cellular baffle and lensed optic to ensure consistent optical performance with excellent glare control and efficiency the Rubini Recessed 12 has been designed without compromise in materials or performance.

The Rubini Recessed 12 is available in white, black or coppered baffle options, compatibility with all common dimming systems and emergency variants incorporating lithium batteries for extended warranty and lifetime. The Rubini Recessed 12 is also available in Reacta-Control and Reacta-Link compatible variants offering wireless grouping and automated emergency testing and reporting.

UK
CA CE ECA IP20 TM21: L90>60K HOURS / L80>100K HOURS 3 STEP MACADAM ELLIPSE

APPLICATION

- Commercial / Offices
- Education
- Hotel / Leisure
- Office
- Retail

SPECIFICATION

CONSTRUCTION

- Housing: High pressure die cast aluminium
- Finish: Polyester powder painted RAL 9016 textura matt white
- Finish: Polyester powder painted RAL 9005 textura matt black
- Lens: Injection moulded PMMA 80° with baffle in RAL9005 matt black, RAL 9016 matt white or copper
- IP20

PERFORMANCE

- Part L2 compliant
- BSEN 12464-1:2011 3000 Candela 65° and UGR 19 compliance
- 3SDCM Three step Macadams ellipse
- TM21: L90>60K Hours / L80>100K Hours
- Up to 143 luminaire lumens per circuit Watt

ENVIRONMENTAL

- Designed to allow simple replacement of components with commonly available tools in compliance with the Eco Design Directive, please see the installation leaflet for maintenance instructions.
- Powered by European branded drivers and emergency modules ensuring replacement parts are easily sourced.
- Every luminaire is labelled with a unique ID number allowing easy identification of spare parts for the lifetime of the product.
- Contains no single use plastics or polystyrene packaging.
- Supplied in plain card boxes with paper tape ensuring packaging is easily recycled.
- Designed to allow simple disassembly for end of life recycling.
- UK based manufacturing providing local support throughout the product lifetime and minimising transportation miles.

EMERGENCY

- Available with optional standard, self test and autotest integral emergency with lithium batteries for extended warranty and lifetime.

- Optional Reacta-Link wireless emergency for automated centralised reporting.
- Optional Reacta-Control wireless emergency for automated centralised reporting.

CONTROL

- HFR 1-10V analogue dimming
- Optional compatibility with a range of dimming systems including DALI, DSI and Switch Dimming
- Optional integral Reacta-Link for integration with Reacta-Link wireless installations
- Optional integral Reacta-Control for integration with Reacta-Control wireless installations

INSTALLATION

- Suitable for plasterboard installation
- Suitable for mineral fibre ceiling tile installation
- Suitable for metal ceiling tile installation

VARIATIONS

- Available with a wide range of colour temperatures and renderings
- Available in white or black finishes

IMAGES

PRODUCT IMAGES



Rubini Recessed 12 White Bezel White Baffle



Rubini Recessed 12 White Bezel Black Baffle



Rubini Recessed 12 White Bezel Copper Baffle

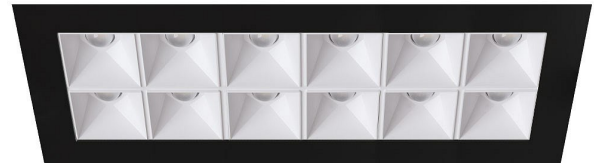

Rubini Recessed 12 Black Bezel White Baffle



Rubini Recessed 12 Black Bezel Black Baffle

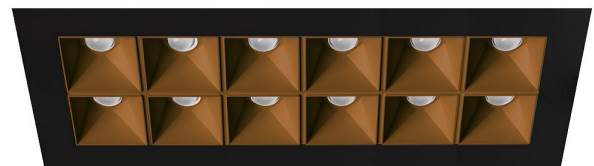

Rubini Recessed 12 Black Bezel Copper Baffle

TECHNICAL

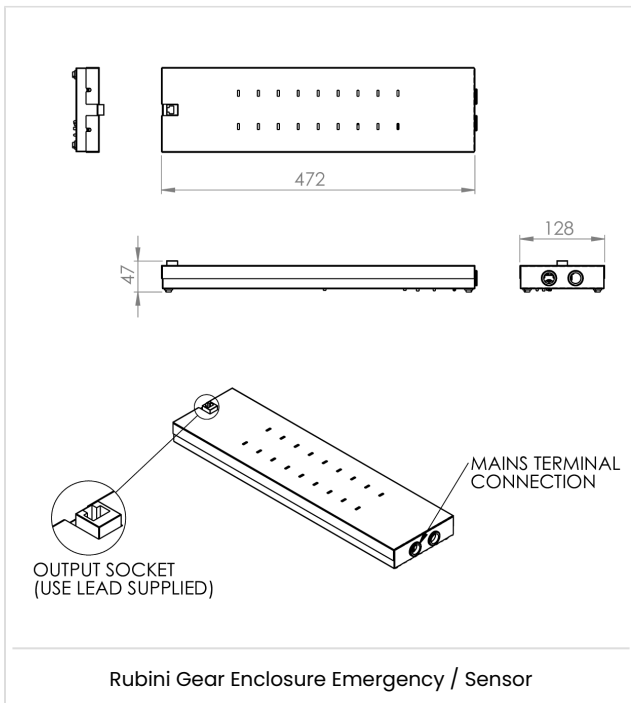
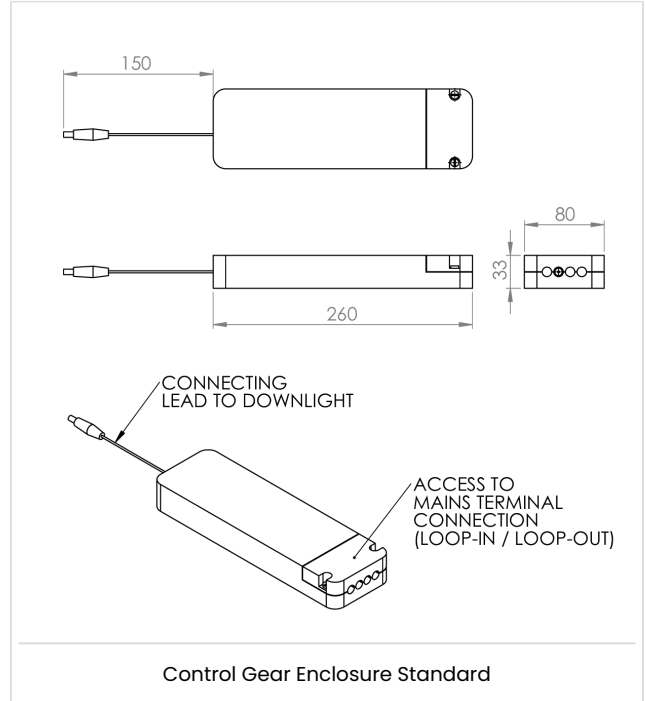
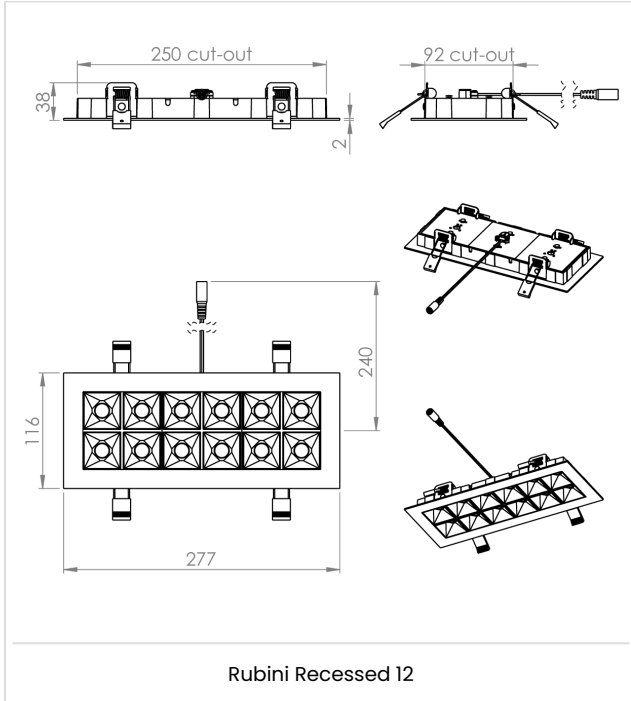

WARRANTY

At Dextra our commitment to service has been at the forefront throughout our history spanning more than forty years in the UK lighting market. Our service ethos extends beyond design and delivery, we believe supporting your installation throughout the warranty period is equally crucial, whilst the strength and longevity of Dextra Group provides peace of mind that our warranty will be supported throughout.

The Dextra range is supplied with a five year warranty commencing from the date of delivery. During the first three years defects will be repaired on site and the warranty will include both parts and labour. For the final two years drivers, emergency modules, wireless modules, sensors and LED circuits will be supplied free of charge to replace defective components, labour and other associated costs are not included.

Certain ranges and components are subject to exemptions:

- ▶ Lithium batteries are provided with a five year warranty. During the first three years defects will be repaired on site and the warranty will include both parts and labour. For the final two years replacement batteries will be supplied free of charge to replace defective components. Five year warranty became effective as of 03/02/25, Lithium emergency luminaires supplied prior to this date are supported with a three year on site warranty only. Labour and other associated costs are not included. Nickel Metal Hydride and Nickel Cadmium batteries are provided with a one year warranty for parts and labour.
- ▶ Emergency luminaires including AME2, EXI LED, EXI3, HBE3, HBE4, OAT2 LED and Twinspace are supplied with a one year warranty for parts and labour. Lithium variants suffixed with the 5YR part code, the Autotest emergency with the LA3 part code and wireless variants with LA3RC or LSTR part codes are supplied with a five year warranty. For these extended warranty variants for the first three years defects will be repaired on site and the warranty will include both parts and labour. For the final two years replacement batteries will be supplied free of charge to replace defective components.
- ▶ Protec Micro, PTECF7 Fire Rated Downlights, Serenus and the Opus Sconce are provided with a five year replacement luminaire only warranty. Protec FR Fire Rated Downlights are provided with a 2 year replacement luminaire only warranty.
- ▶ Controls systems such as standalone sensors, switches, marshalling boxes and cabling are provided with a one year warranty for both parts and labour. DALI control systems are provided with a two year warranty for both parts and labour.
- ▶ LEDextra ranges are supplied with a three year parts or replacement luminaire only warranty with the exception of the IMPR RGBW, the Runway RGBW, the MOD RGBW, Tanek RGBW and the DexRing. These five ranges are supplied with our standard five year warranty during which defects within the first three years will be repaired on site and the warranty includes both parts and labour. For the final two years free of charge replacement components only will be supplied to rectify any failures but labour and other associated costs are not included.
- ▶ LEDEX ranges are supplied with a three year replacement luminaire only warranty.
- ▶ The Decorative Pendant ranges, Bebo, Dene, Nova, Fino and Stix are supplied with a 3 year replacement luminaire only warranty.

All warranties are subject to correct use of the product and will be invalidated by misuse, for example incorrect installation, unsuitable environmental conditions or incorrect maintenance. It is the duty of the customer to ensure that all the fault lies with the luminaire prior to requesting replacement parts or site repairs. In the event that no defect is found with the product our costs for attending site will be recharged to the customer and credit

will not be issued against returned products. No consequential losses incurred resulting from any defect with our product will be reimbursed.

Given the nature of LED technology a small percentage of LEDs may fail during the lifetime of a luminaire, this does not cause a reduction in lumen output. As such LED luminaires are only deemed to be faulty for warranty purposes when in excess of ten percent of LEDs have failed in a single luminaire.

On site repair of products under warranty will be undertaken during normal working hours, 9am to 5pm Monday to Friday, and will require unrestricted access to luminaires. Where required Dextra will provide access equipment to carry out repairs at height, should luminaires have been installed in locations where reasonable provision for maintenance access has not been made we reserve the right to supply replacement product only. On site warranty repairs will only be undertaken on the mainland of the UK and Ireland, in all other locations replacement product only will be provided.

If you require any assistance with regards to our products please contact our Customer Services department on 01747 858100.

ORDER CODES

LUMINAIRE

Code	Description	Power	Llm/W
RBNR12 L33 **	Rubini Recessed 12 Cell, 2,843llm, Colour 84	19.9W	143
RBNR12 L51 **	Rubini Recessed 12 Cell, 4,394llm, Colour 84	30.8W	143

llm/W figures relate to white baffle options

COLOUR

Code	Description
WW	White Housing / White Baffle
WB	White Housing / Black Baffle
WC	White Housing / Copper Baffle
BB	Black Housing / Black Baffle
BW	Black Housing / White Baffle
BC	Black Housing / Copper Baffle

DIMMING

Code	Description
A	DALI Digital Addressable Lighting Interface
S	Switch Dimming
D	DSI Digital Dimming
H	HFR Analogue 1-10v

CONTROL

Code	Description
DN	DexNET Node, Wireless Node only.
RLI	Reacta-Link, Wireless Enabled Luminaire
RC	Reacta-Control, Wireless Enabled Luminaire

Please click [here](#) for full details on our wireless controls.

EMERGENCY

Code	Description
LE3	Lithium Standard Emergency 3 Hour
LS3	Lithium Selftest Emergency 3 Hour
LA3	Lithium Autotest Emergency 3 Hour
LA3D	Lithium DexNET Emergency 3 Hour
LSTR	Lithium Reacta-Link Emergency 3 Hour
LA3RC	Lithium Reacta-Control Emergency 3 Hour

MISCELLANEOUS

Code	Description
C**	Select Colour Temperature and Rendering; C827, C83, C85, C865, C93, C94
4PM	4 Pole Panel Mount
6PM	6 Pole Panel Mount
LSF	Low Smoke Zero Halogen

CRI 90 variants are only available in limited options

220-240V / 50-60Hz
IP20



WARNING: Luminaire must be earthed. Risk of electric shock from LED boards if operated with cover removed. Installation / operation outside of luminaires intended scope invalidates warranty. Suitable only for domestic / light industrial / industrial applications within the scope of EN55015. Tested to compliance with BSEN 60598: specification for general requirements and tests. Must be installed by a suitably qualified person in accordance with all relevant legislation. Ambient operating temperature of 0°C to 25°C. If maximum operating temperature is exceeded luminaire will automatically dim / switch off. Terminal blocks are rated to 16A unless stated otherwise. The light source contained in this luminaire shall only be replaced by the manufacturer or his service agent or a similar qualified person. **LUMINAIRES WITH EMERGENCY PACK:** When supply is isolated battery output terminals may be live if battery is connected. Isolate mains and battery before servicing. Emergency luminaires require unswitched live connection taken from same phase as switched supply. When unswitched supply is connected status indicator illuminates green, when unswitched supply is disconnected indicator extinguishes and luminaire operates in emergency mode. 24 hour charge period required before undertaking full discharge test. Emergency test sheets provided should be used to record all emergency tests. Batteries should be replaced when 3 hour duration is not met. Excessive switching of permanent live may result in premature battery failure. Battery electrolyte can be harmful to eyes / open wounds, do not puncture, if electrolyte touches skin / eyes flush with water. Do not incinerate batteries.

Terminal Labelling:

Power	
L1	Switched Live
E	Earth
N	Neutral
Emergency	
L2	Unswitched Live
DA/AT3	DALI Autotest
DA/AT3	DALI Autotest
Dimming	
-/D1/DA	Analogue/DSI/DALI
+/D2/DA	Analogue/DSI/DALI
L3	Switch Dim / Corridor Function

1.

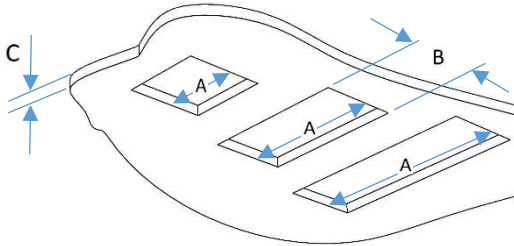

	A	B	C
RBNR4	92	92	1-20
RBNR8	171	92	1-20
RBNR12	251	92	1-20

2.

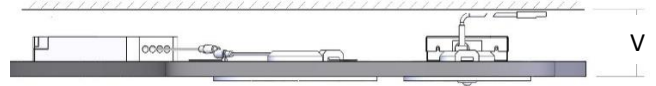

Min void 'V' (inc. 20mm thickness)

RBNR4	125mm
RBNR8	75mm
RBNR12	60mm

3.

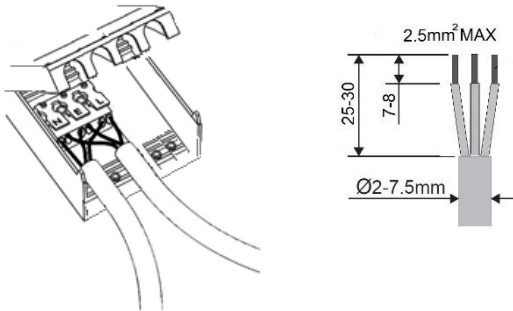

Remote control gear pack has 'piano-key' type terminal blocks allowing for loop-in / loop-out connection... NOTE this may be pre-wired depending on variant supplied!

4.

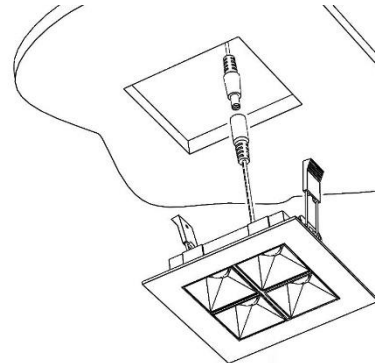

After passing remote gear pack through cut-out, connect leads as shown... retract springs fully and offer fixture in to ceiling aperture

5.

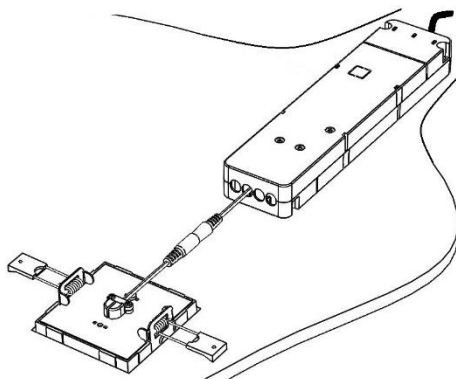

6.

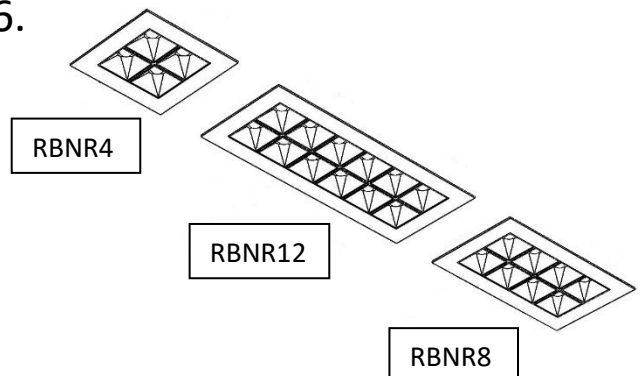

Maintenance

1. Disconnect luminaire before undertaking any maintenance or cleaning.
2. Cleaning should be undertaken on external parts of the luminaire only, using a slightly damp lint free cloth.
3. To access gear box and remove components use a pan pozi screw driver. For emergency remote box remove screw and slide cover out.
4. To access LED circuit, use a flat headed screwdriver to remove rivets from springs and back of fitting. Circuit can then be removed from housing.

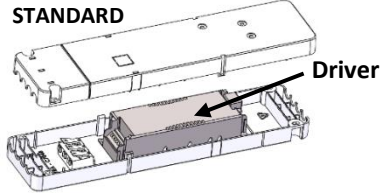

5. Please contact Dextra for assistance with spare component supply.

