



PRODUCT SPECIFICATION

PROSPORT



INTRODUCTION

In any sporting application high quality lighting is critical to ensure a satisfactory player experience. The Prosport offers a range of distributions and up to 38,592lm luminaire lumens output allowing your scheme to be designed to give optimum light levels and uniformity whilst offering excellent energy efficiency and low maintenance compared to fluorescent and HID sources. The Prosport is IK10 rated and manufactured with a steel housing, injection moulded polycarbonate end caps and a curved clear polycarbonate diffuser ensuring that the luminaire is robust, durable and able to withstand ball strikes from most sports whilst eliminating the risk of shattered lamps which can occur with fluorescent or HID luminaires. The angled housing is designed to be both aesthetically pleasing and to minimise the risk of balls or shuttlecocks lodging on the rear. The Prosport is available with a wide range of dimming options as well as integral lithium emergency. We offer a range of wireless control systems providing localised grouping and control as well as comprehensive wireless solutions allowing both standard and emergency luminaires to be centrally monitored.

Two body sizes are available, 1500mm and 1000mm in a range of lumen outputs in both symmetrical and asymmetrical versions allowing the luminaire to be used for general sports hall lighting or for court sports such as tennis and badminton.



CE IP40 IK10 TM21: L90>60K HOURS / L80>100K HOURS 3 STEP MACADAM ELLIPSE

APPLICATION

- Education
- Hotel / Leisure
- Sports Hall

SPECIFICATION

CONSTRUCTION

- Housing: 0.8mm HC220 steel
- Finish: Polyester powder painted RAL 9016 textura matt white
- Endcaps: Injection moulded polycarbonate
- Diffuser: 2mm clear polycarbonate
- IK10
- IP40

PERFORMANCE

- Part L2 compliant
- 3SDCM Three step Macadams ellipse
- TM21: L90>60K Hours / L80>100K Hours
- Up to 149 luminaire lumens per circuit Watt.

ENVIRONMENTAL

- Designed to allow simple replacement of components with commonly available tools in compliance with the Eco Design Directive, please see the installation leaflet for maintenance instructions.
- Powered by European branded drivers and emergency modules ensuring replacement parts are easily sourced.
- Every luminaire is labelled with a unique ID number allowing easy identification of spare parts for the lifetime of the product.
- Contains no single use plastics or polystyrene packaging.
- Supplied in plain card boxes with paper tape ensuring packaging is easily recycled.
- Designed to allow simple disassembly for end of life recycling.
- UK based manufacturing providing local support throughout the product lifetime and minimising transportation miles.

EMERGENCY

- Available with optional standard, self test and autotest integral emergency with lithium batteries for extended warranty and lifetime.
- Optional Reacta-Link wireless emergency for automated centralised reporting.
- Optional Reacta-Control wireless emergency for automated centralised reporting.

- Optional central battery changeover relay

CONTROL

- Optional compatibility with a range of dimming systems including DALI, DSI and Switch Dimming
- Optional integral Reacta-Link for integration with Reacta-Link wireless installations
- Optional integral Reacta-Control for integration with Reacta-Control wireless installations

INSTALLATION

- Suitable for suspended installation
- Suitable for trunking installation
- Rigid suspension is required in areas where ball strikes may occur.
- Please note that the cricket applications should use protective netting to prevent ball strikes to the Prosport LED.

VARIATIONS

- Available with a wide range of colour temperatures and renderings
- Available in a range of housing sizes and lumen outputs

IMAGES

PRODUCT IMAGES



PROJECT IMAGES



Exmouth Tennis Centre using the Pro Sport



Exmouth Tennis Centre using the Pro Sport



Teddington School using the Pro Sport

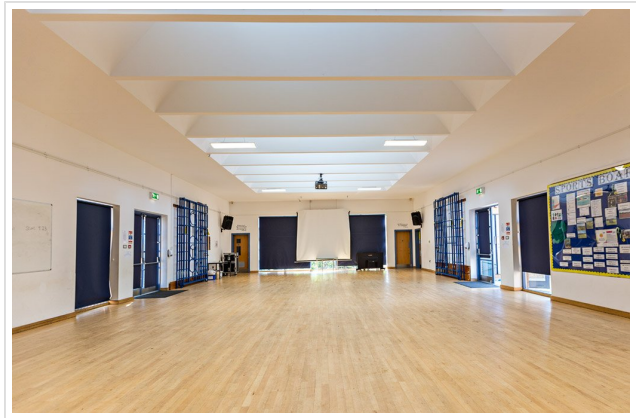

Emerson Valley using the Pro Sport LED

TECHNICAL

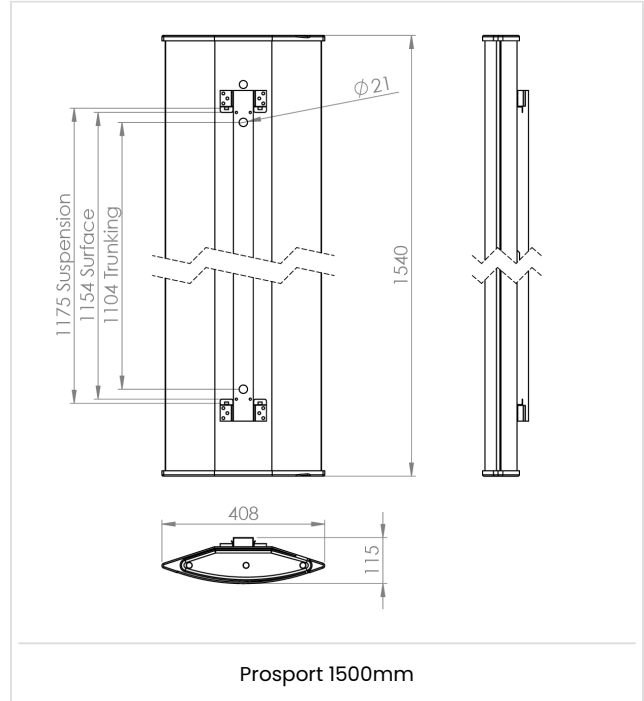
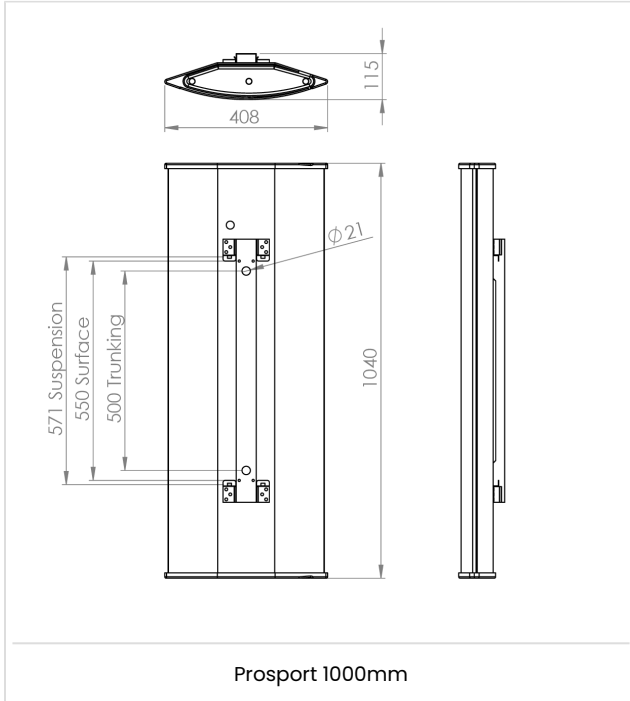

WARRANTY

At Dextra our commitment to service has been at the forefront throughout our history spanning more than forty years in the UK lighting market. Our service ethos extends beyond design and delivery, we believe supporting your installation throughout the warranty period is equally crucial, whilst the strength and longevity of Dextra Group provides peace of mind that our warranty will be supported throughout.

The Dextra range is supplied with a five year warranty commencing from the date of delivery. During the first three years defects will be repaired on site and the warranty will include both parts and labour. For the final two years drivers, emergency modules, wireless modules, sensors and LED circuits will be supplied free of charge to replace defective components, labour and other associated costs are not included.

Certain ranges and components are subject to exemptions:

- ▶ Lithium batteries are provided with a five year warranty. During the first three years defects will be repaired on site and the warranty will include both parts and labour. For the final two years replacement batteries will be supplied free of charge to replace defective components. Five year warranty became effective as of 03/02/25, Lithium emergency luminaires supplied prior to this date are supported with a three year on site warranty only. Labour and other associated costs are not included. Nickel Metal Hydride and Nickel Cadmium batteries are provided with a one year warranty for parts and labour.
- ▶ Emergency luminaires including AME2, EXI LED, EXI3, HBE3, HBE4, OAT2 LED and Twinspace are supplied with a one year warranty for parts and labour. Lithium variants suffixed with the 5YR part code, the Autotest emergency with the LA3 part code and wireless variants with LA3RC or LSTR part codes are supplied with a five year warranty. For these extended warranty variants for the first three years defects will be repaired on site and the warranty will include both parts and labour. For the final two years replacement batteries will be supplied free of charge to replace defective components.
- ▶ Protec Micro, PTECF7 Fire Rated Downlights, Serenus and the Opus Sconce are provided with a five year replacement luminaire only warranty. Protec FR Fire Rated Downlights are provided with a 2 year replacement luminaire only warranty.
- ▶ Controls systems such as standalone sensors, switches, marshalling boxes and cabling are provided with a one year warranty for both parts and labour. DALI control systems are provided with a two year warranty for both parts and labour.
- ▶ LEDextra ranges are supplied with a three year parts or replacement luminaire only warranty with the exception of the IMPR RGBW, the Runway RGBW, the MOD RGBW, Tanek RGBW and the DexRing. These five ranges are supplied with our standard five year warranty during which defects within the first three years will be repaired on site and the warranty includes both parts and labour. For the final two years free of charge replacement components only will be supplied to rectify any failures but labour and other associated costs are not included.
- ▶ LEDEX ranges are supplied with a three year replacement luminaire only warranty.
- ▶ The Decorative Pendant ranges, Bebo, Dene, Nova, Fino and Stix are supplied with a 3 year replacement luminaire only warranty.

All warranties are subject to correct use of the product and will be invalidated by misuse, for example incorrect installation, unsuitable environmental conditions or incorrect maintenance. It is the duty of the customer to ensure that all the fault lies with the luminaire prior to requesting replacement parts or site repairs. In the event that no defect is found with the product our costs for attending site will be recharged to the customer and credit

will not be issued against returned products. No consequential losses incurred resulting from any defect with our product will be reimbursed.

Given the nature of LED technology a small percentage of LEDs may fail during the lifetime of a luminaire, this does not cause a reduction in lumen output. As such LED luminaires are only deemed to be faulty for warranty purposes when in excess of ten percent of LEDs have failed in a single luminaire.

On site repair of products under warranty will be undertaken during normal working hours, 9am to 5pm Monday to Friday, and will require unrestricted access to luminaires. Where required Dextra will provide access equipment to carry out repairs at height, should luminaires have been installed in locations where reasonable provision for maintenance access has not been made we reserve the right to supply replacement product only. On site warranty repairs will only be undertaken on the mainland of the UK and Ireland, in all other locations replacement product only will be provided.

If you require any assistance with regards to our products please contact our Customer Services department on 01747 858100.

ORDER CODES

LUMINAIRE

| Code | Description | Power | lIm/W |
|----------|--|--------|-------|
| PRO L120 | Prosport, 1040mm, 9,504lIm, Colour 84 | 63.7W | 149 |
| PRO L170 | Prosport, 1040mm, 13,466lIm, Colour 84 | 95.9W | 140 |
| PRO L240 | Prosport, 1040mm, 19,037lIm, Colour 84 | 138.4W | 137 |
| PRO L345 | Prosport, 1540mm, 27,740lIm, Colour 84 | 199.9W | 139 |
| PRO L480 | Prosport, 1540mm, 38,592lIm, Colour 84 | 276.0W | 139 |

DIMMING

| Code | Description |
|------|---|
| A | DALI Digital Addressable Lighting Interface |
| S | Switch Dimming |
| D | DSI Digital Dimming |
| H | HFR Analogue 1-10v |
| C | Bi-Level Dimming For Standalone Switched Sensor |

The Prosport L345 and L480 use two drivers per luminaire requiring two addresses on the DALI network.

CONTROL

| Code | Description |
|------|--|
| DN | DexNET Node, Wireless Node only. |
| RLI | Reacta-Link, Wireless Enabled Luminaire |
| RC | Reacta-Control, Wireless Enabled Luminaire |

Please click [here](#) for full details on our wireless controls.

EMERGENCY

| Code | Description |
|-------|--|
| LE3 | Lithium Standard Emergency 3 Hour |
| LS3 | Lithium Selftest Emergency 3 Hour |
| LA3 | Lithium Autotest Emergency 3 Hour |
| LA3D | Lithium DexNET Emergency 3 Hour |
| LSTR | Lithium Reacta-Link Emergency 3 Hour |
| LA3RC | Lithium Reacta-Control Emergency 3 Hour |
| CB | Central Battery, Please Specify 110V or 230V when Ordering |

MISCELLANEOUS

| Code | Description |
|-------------------|--|
| C** | Select Colour Temperature and Rendering: C83, C85, C865, C93, C94 |
| LSF | Low Smoke Zero Halogen |
| AS | Asymmetric 20° Bracket (Not suitable for suspension) |
| SUSP PRO 5M LO X2 | 5M Loop Over Suspension Kit (Two Drops) (Not suitable for sports applications) |

Prosport Installation

220-240V / 50-60Hz

IP20

IK10

Terminal Labelling:

Power

L1 Switched Live
E Earth
N Neutral

Emergency

L2 Unswitched Live
DA/AT3 DALI Autotest
DA/AT3 DALI Autotest

Dimming

-/D1/DA Analogue/DSI/DALI
+/D2/DA Analogue/DSI/DALI
L3 Switch Dim / Corridor Function



WARNING: Luminaire must be earthed. Risk of electric shock from LED boards if operated with cover removed. Installation / operation outside of luminaires intended scope invalidates warranty. Suitable only for domestic / light industrial / industrial applications within the scope of EN55015. Tested to compliance with BSEN 60598: specification for general requirements and tests. Must be installed by a suitably qualified person in accordance with all relevant legislation. Ambient operating temperature of 0°C to 25°C. If maximum operating temperature is exceeded luminaire will automatically dim / switch off. Terminal blocks are rated to 16A unless stated otherwise. The light source contained in this luminaire shall only be replaced by the manufacturer itself or his service agent or a similar qualified person. **LUMINAIRES WITH EMERGENCY PACK:** When supply is isolated battery output terminals may be live if battery is connected. Isolate mains and battery before servicing. Emergency luminaires require unswitched live connection taken from same phase as switched supply. When unswitched supply is connected status indicator illuminates green, when unswitched supply is disconnected indicator extinguishes and luminaire operates in emergency mode. 24 hour charge period required before undertaking full discharge test. Emergency test sheets provided should be used to record all emergency tests. Batteries should be replaced when 3 hour duration is not met. Excessive switching of permanent live may result in premature battery failure. Battery electrolyte can be harmful to eyes / open wounds, do not puncture, if electrolyte touches skin / eyes flush with water. Do not incinerate batteries.

1.

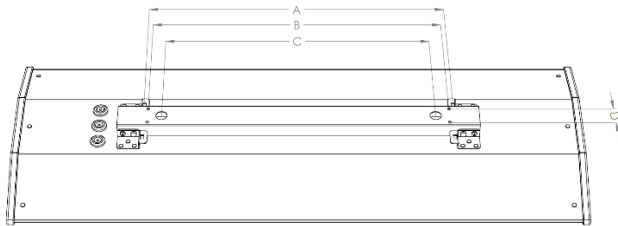

| A | B | C | D |
|------------|-------------|--------------|-------------|
| 568 | 550 | 500 | 35 |
| Suspension | Surface Fix | Trunking Fix | Surface Fix |

2.

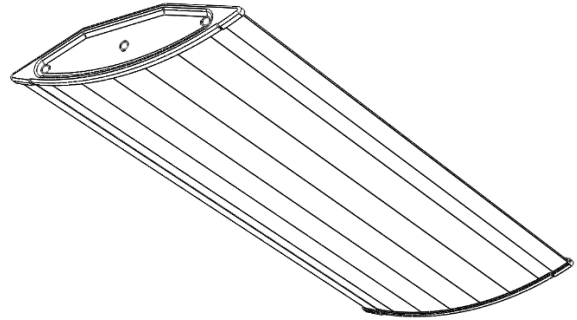

Weight

11kg

(+1kg for Emergency version)

3.

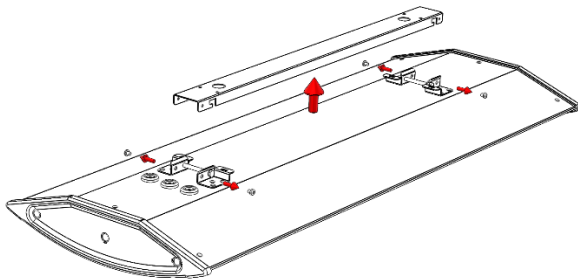

Remove 4x M5 PanPozi screws to release the mounting spine form rear of fitting. Do not remove M6 bolts.

Note. This does not need to be done if fitting is suspended – skip to **section 4B** and installation complete.

4a.

Secure mounting spine into position using one of these suggested fixing methods (A, B, C).

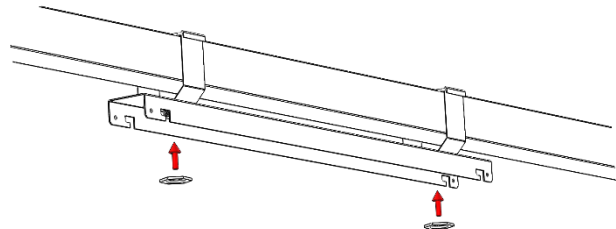

Trunking mounted via 2x M20 brass bush and securing nut.

4b.

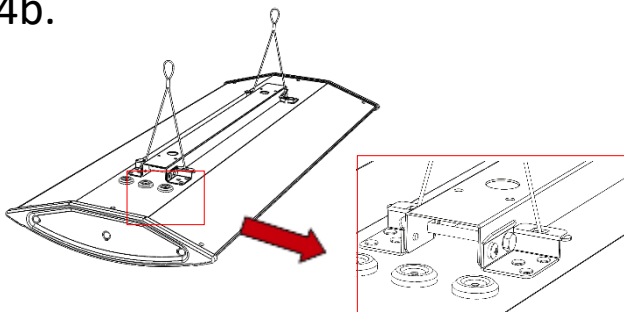

Suspension Toggles (Not supplied).

Suspension kits should not be used where luminaires may be subject to ball impacts, rigid mounting is recommended in these applications

4c.

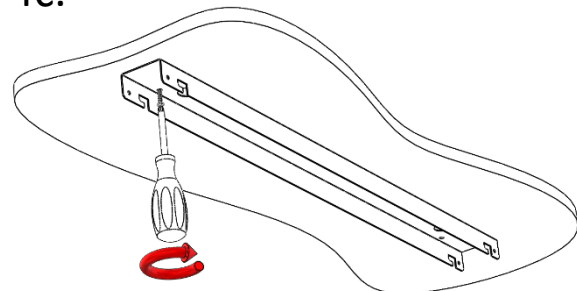

Surface mounted via 4x appropriate screw fixings into solid ceiling.

Prosport Installation

5.

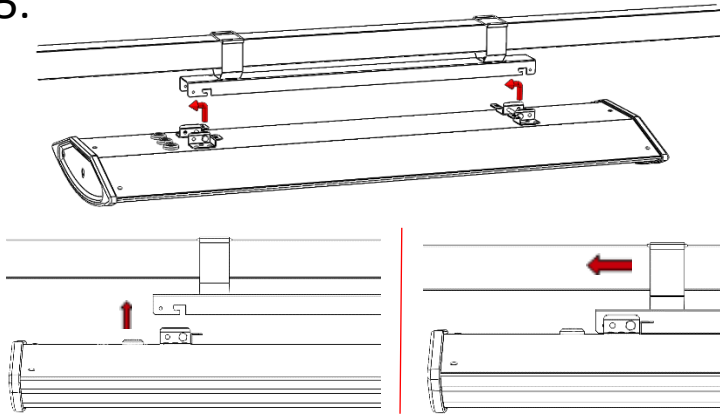

Re-engage light fitting to mounting spine. Lift vertically into slots and the slide horizontally to hook suspend fitting.

Be very careful not to knock fitting from hooked position prior to Step 8.

6.

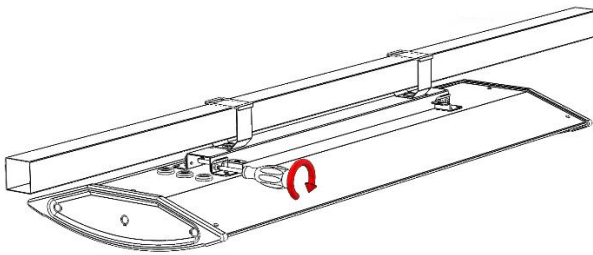

Re-fasten 4x M5 PanPozi screws removed in Step1. All fittings come pre-wired, electrical connection can be made post install.

7. Please note the following diagrams when wiring a luminaire with a pre wired flex.

Central Battery

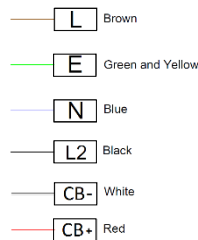

Central Battery DALI

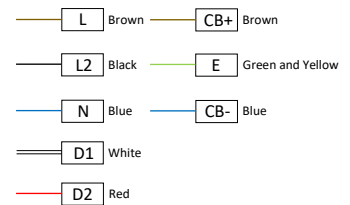

8.

STANDARD

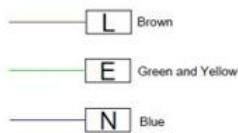

SWITCH DIM

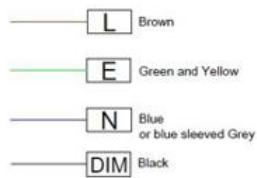

DALI/DSI

FLEX: Brown/GY/Blue/White/Red

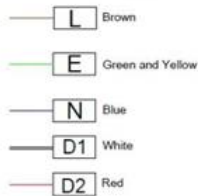

STANDARD: DOUBLE SWITCHED

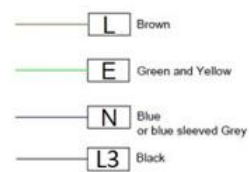

9.

EMERGENCY

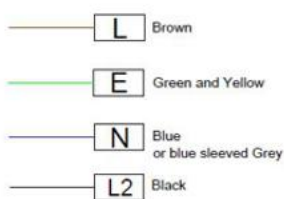

SWITCH DIM

FLEX: Brown/GY/Blue/Red/White

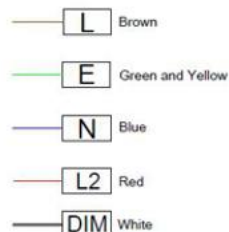

DALI/DSI

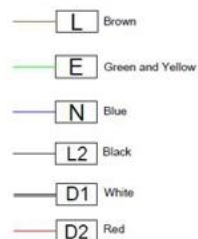

EMERGENCY: DOUBLE SWITCHED

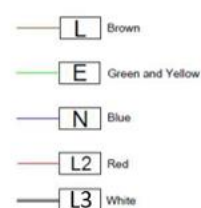

Prosport Installation

Maintenance

- 1 Disconnect luminaire before undertaking any maintenance or cleaning.
- 2 Cleaning should be undertaken on external parts of the luminaire only using a slightly damp lint free cloth.
- 3 To access fitting use a pan pozi screwdriver to remove screws from endcaps, then remove endcap.
- 4 Slide diffuser out from one end of fitting.
- 5 To remove gear cover and components use a pan pozi screwdriver
- 6 Use a pan pozi screwdriver to remove lens to access LED circuits.
- 7 Please contact Dextra for assistance with spare component supply.

