



# PRODUCT SPECIFICATION

---

MOD SURFACE



---

## INTRODUCTION

---

The MOD Surface / Suspended is a traditional flat panel luminaire with uniformly lit diffuser using backlit technology ensuring superb efficiency as well as benefitting LED lifetime by using a high chip count run at low output to minimise operating temperature. This range is available in three housing sizes, a wide range of lumen outputs, dimming and lithium emergency variants and can be either suspended or surface mounted. We offer a range of wireless control systems providing localised grouping and control as well as comprehensive wireless solutions allowing both standard and emergency luminaires to be centrally monitored.

The combination of energy efficiency, flexibility and attractive minimalist design makes the MODLED Surface / Suspended an excellent choice for installations where the client demands an appealing aesthetic with premium.

**UK**  
**CA** CE IP40 TM21: L90>60K HOURS / L80>100K HOURS 3 STEP MACADAM ELLIPSE

---

## APPLICATION

---

- Canteen
- Commercial / Offices
- Corridor
- Education
- Healthcare / Social Housing
- Hotel / Leisure
- Industrial / Manufacturing
- Office
- Retail
- Transport
- Warehousing

---

## SPECIFICATION

---

### CONSTRUCTION

- Housing: 0.7mm CR4 steel
- Finish: Polyester powder painted RAL 9016 textura matt white
- Diffuser: 2mm high transmission opal polycarbonate TP(a) rated
- IK08
- IP40

### PERFORMANCE

- Part L2 compliant
- BSEN 12464-1:2011 3000 Candela 65° and UGR 19 compliance
- 3SDCM Three step Macadams ellipse
- TM21: L90>60K Hours / L80>100K Hours
- Up to 146 luminaire lumens per circuit Watt.

### ENVIRONMENTAL

- Designed to allow simple replacement of components with commonly available tools in compliance with the Eco Design Directive, please see the installation leaflet for maintenance instructions.
- All critical components are mounted on a single tray for simple end of life repair or upgrade.
- Powered by European branded drivers and emergency modules ensuring replacement parts are easily sourced.
- Every luminaire is labelled with a unique ID number allowing easy identification of spare parts for the lifetime of the product.
- Contains no single use plastics or polystyrene packaging.

- Supplied in plain card boxes with paper tape ensuring packaging is easily recycled.
- Designed to allow simple disassembly for end of life recycling.
- UK based manufacturing providing local support throughout the product lifetime and minimising transportation miles.

### EMERGENCY

- Available with optional standard, self test and autotest integral emergency with lithium batteries for extended warranty and lifetime.
- Optional Reacta-Link wireless emergency for automated centralised reporting.
- Optional Reacta-Control wireless emergency for automated centralised reporting.
- Optional central battery changeover relay

### CONTROL

- Optional compatibility with a range of dimming systems including DALI, DSI and Switch Dimming
- Optional White tunable
- Optional Integral Reacta-Air wireless presence and daylight regulations sensor
- Optional integral Reacta-Link for integration with Reacta-Link wireless installations
- Optional integral Reacta-Control for integration with Reacta-Control wireless installations

### INSTALLATION

- Suitable for surface installation

### VARIATIONS

- Available with a wide range of colour temperatures and renderings
- Available in a range of housing sizes and lumen outputs
- Available with optional night light

**IMAGES**

PRODUCT IMAGES



### PROJECT IMAGES



Bournemouth University using the MODLED Suspended and MODLED Recessed



Liverpool John Lennon airport using the MODLED Surface



Liverpool John Lennon airport using the MODLED Surface



Liverpool John Lennon airport using the MODLED Surface

TECHNICAL

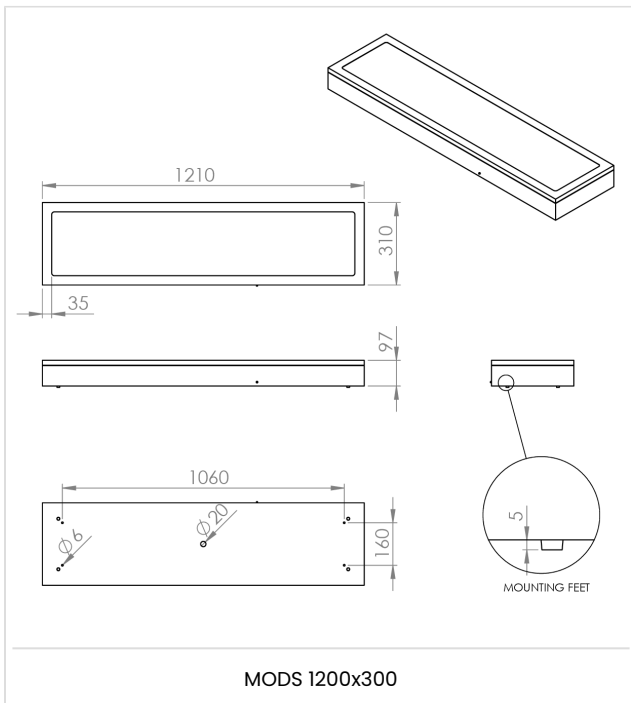
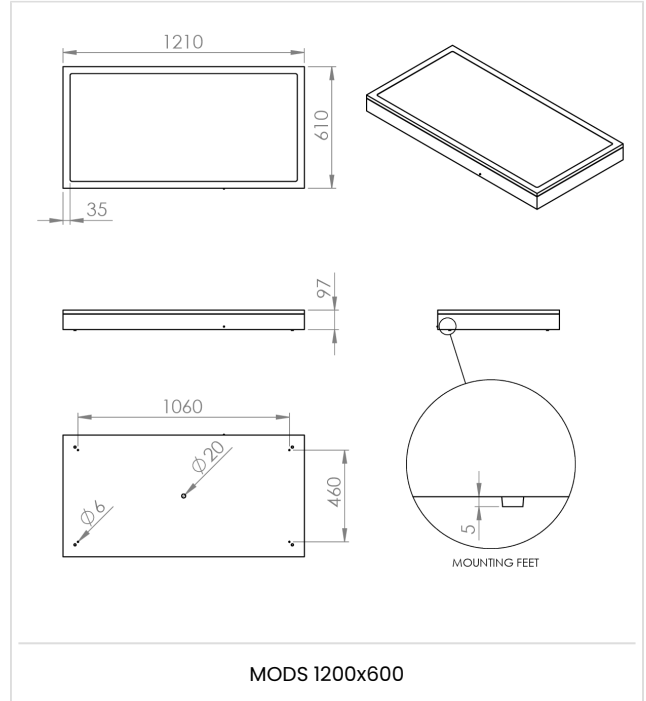
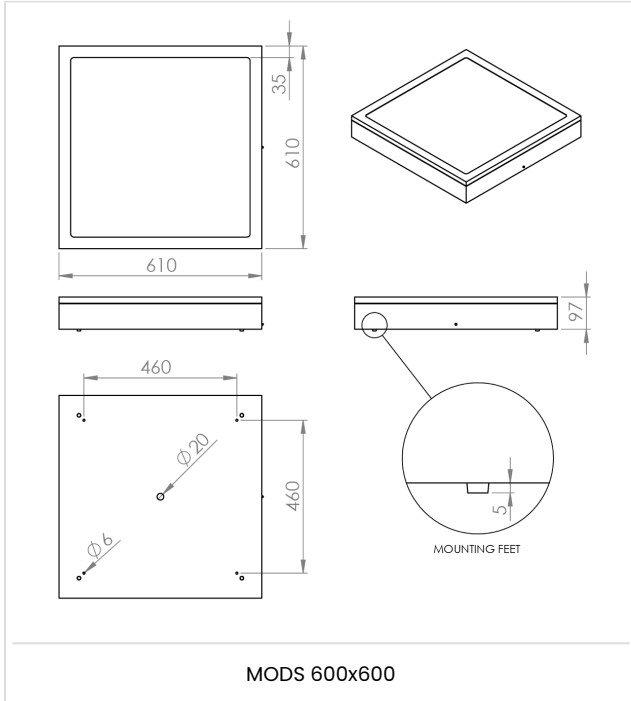

---

## WARRANTY

---

At Dextra our commitment to service has been at the forefront throughout our history spanning more than forty years in the UK lighting market. Our service ethos extends beyond design and delivery, we believe supporting your installation throughout the warranty period is equally crucial, whilst the strength and longevity of Dextra Group provides peace of mind that our warranty will be supported throughout.

The Dextra range is supplied with a five year warranty commencing from the date of delivery. During the first three years defects will be repaired on site and the warranty will include both parts and labour. For the final two years drivers, emergency modules, wireless modules, sensors and LED circuits will be supplied free of charge to replace defective components, labour and other associated costs are not included.

Certain ranges and components are subject to exemptions:

- ▶ Lithium batteries are provided with a five year warranty. During the first three years defects will be repaired on site and the warranty will include both parts and labour. For the final two years replacement batteries will be supplied free of charge to replace defective components. Five year warranty became effective as of 03/02/25, Lithium emergency luminaires supplied prior to this date are supported with a three year on site warranty only. Labour and other associated costs are not included. Nickel Metal Hydride and Nickel Cadmium batteries are provided with a one year warranty for parts and labour.
- ▶ Emergency luminaires including AME2, EXI LED, EXI3, HBE3, HBE4, OAT2 LED and Twinspace are supplied with a one year warranty for parts and labour. Lithium variants suffixed with the 5YR part code, the Autotest emergency with the LA3 part code and wireless variants with LA3RC or LSTR part codes are supplied with a five year warranty. For these extended warranty variants for the first three years defects will be repaired on site and the warranty will include both parts and labour. For the final two years replacement batteries will be supplied free of charge to replace defective components.
- ▶ Protec Micro, PTECF7 Fire Rated Downlights, Serenus and the Opus Sconce are provided with a five year replacement luminaire only warranty. Protec FR Fire Rated Downlights are provided with a 2 year replacement luminaire only warranty.
- ▶ Controls systems such as standalone sensors, switches, marshalling boxes and cabling are provided with a one year warranty for both parts and labour. DALI control systems are provided with a two year warranty for both parts and labour.
- ▶ LEDextra ranges are supplied with a three year parts or replacement luminaire only warranty with the exception of the IMPR RGBW, the Runway RGBW, the MOD RGBW, Tanek RGBW and the DexRing. These five ranges are supplied with our standard five year warranty during which defects within the first three years will be repaired on site and the warranty includes both parts and labour. For the final two years free of charge replacement components only will be supplied to rectify any failures but labour and other associated costs are not included.
- ▶ LEDEX ranges are supplied with a three year replacement luminaire only warranty.
- ▶ The Decorative Pendant ranges, Bebo, Dene, Nova, Fino and Stix are supplied with a 3 year replacement luminaire only warranty.

All warranties are subject to correct use of the product and will be invalidated by misuse, for example incorrect installation, unsuitable environmental conditions or incorrect maintenance. It is the duty of the customer to ensure that all the fault lies with the luminaire prior to requesting replacement parts or site repairs. In the event that no defect is found with the product our costs for attending site will be recharged to the customer and credit

will not be issued against returned products. No consequential losses incurred resulting from any defect with our product will be reimbursed.

Given the nature of LED technology a small percentage of LEDs may fail during the lifetime of a luminaire, this does not cause a reduction in lumen output. As such LED luminaires are only deemed to be faulty for warranty purposes when in excess of ten percent of LEDs have failed in a single luminaire.

On site repair of products under warranty will be undertaken during normal working hours, 9am to 5pm Monday to Friday, and will require unrestricted access to luminaires. Where required Dextra will provide access equipment to carry out repairs at height, should luminaires have been installed in locations where reasonable provision for maintenance access has not been made we reserve the right to supply replacement product only. On site warranty repairs will only be undertaken on the mainland of the UK and Ireland, in all other locations replacement product only will be provided.

**If you require any assistance with regards to our products please contact our Customer Services department on 01747 858100.**

## ORDER CODES

### LUMINAIRE

Code	Description	Power	Llm/W
MODS L29	MOD Surface/Suspended, 600x600, 1,981lm, Colour 84*.	15.1W	131
MODS L35	MOD Surface/Suspended, 600x600, 2,390lm, Colour 84*.	17.9W	134
MODS L45	MOD Surface/Suspended, 600x600, 3,073lm, Colour 84.	22.5W	137
MODS L68	MOD Surface/Suspended, 600x600, 4,644lm, Colour 84.	35.0W	133
MODS 123 L35	MOD Surface/Suspended, 1200x300, 2,391lm, Colour 84*.	17.9W	134
MODS 123 L45	MOD Surface/Suspended, 1200x300, 3,073lm, Colour 84.	22.5W	137
MODS 123 L68	MOD Surface/Suspended, 1200x300, 4,644lm, Colour 84.	35.0W	133
MODS 126 L58	MOD Surface/Suspended, 1200x600, 3,961lm, Colour 84*.	27.1W	146
MODS 126 L70	MOD Surface/Suspended, 1200x600, 4,780lm, Colour 84*.	33.8W	141
MODS 126 L90	MOD Surface/Suspended, 1200x600, 6,147lm, Colour 84.	41.5W	148
MODS 126 L136	MOD Surface/Suspended, 1200x600, 9,288lm, Colour 84.	66.9W	139

\*BSEN 12464 compliant options. Please see the MOD Office and MOD UGR for a wider range of glare compliant luminaires.

### DIMMING

Code	Description
A	DALI Digital Addressable Lighting Interface
S	Switch Dimming
D	DSI Digital Dimming
H	HFR Analogue 1-10v
C	Bi-Level Dimming For Standalone Switched Sensor
WT	White Tunable (Lumen Outputs Vary from Standard)

Please click [here](#) for full details on our white tunable offer.

### CONTROL

Code	Description
D44	DexNET Sensor, Wireless, Presence & Daylight, 2.5-5M
DN	DexNET Node, Wireless Node only.
RAS	Reacta-Air Bluetooth, Wireless, Presence & Daylight, 2.5-3M
RLI	Reacta-Link, Wireless Enabled Luminaire
RLS	Reacta-Link Wireless, Presence & Daylight, 2.5M-5M
RC	Reacta-Control, Wireless Enabled Luminaire
RCS	Reacta-Control Wireless, Presence & Daylight, 2.5-4M

Please click [here](#) for full details on our wireless controls.

### EMERGENCY

Code	Description
LE3	Lithium Standard Emergency 3 Hour
LS3	Lithium Selftest Emergency 3 Hour
LA3	Lithium Autotest Emergency 3 Hour
LA3D	Lithium DexNET Emergency 3 Hour
LSTR	Lithium Reacta-Link Emergency 3 Hour
LA3RC	Lithium Reacta-Control Emergency 3 Hour
CB	Central Battery, Please Specify 110V or 230V when Ordering

### MISCELLANEOUS

Code	Description
------	-------------

C**	Select Colour Temperature and Rendering; C827, C83, C85, C865, C93, C94
SUSP 4 POINT 3M BF X4	Four Point Suspension Kit
LSF	Low Smoke Zero Halogen

## MOD Surface Installation

220-240V / 50-60Hz  
IP20



**Terminal Labelling:**

<b>Power</b>	
L / 1	Switched Live
E / ⊕	Earth
N	Neutral
<b>Emergency</b>	
L2 / 2	Unswitched Live
DA/AT3	DALI Autotest
DA/AT3	DALI Autotest
<b>Dimming</b>	
-/D1/DA	Analogue/DSI/DALI
+/D2/DA	Analogue/DSI/DALI
SD	Switch Dim / Corridor Function

**WARNING:** Luminaire must be earthed. Risk of electric shock from LED boards if operated with cover removed. Installation / operation outside of luminaires intended scope invalidates warranty. Suitable only for domestic / light industrial / industrial applications within the scope of EN55015. Tested to compliance with BSEN 60598: specification for general requirements and tests. Must be installed by a suitably qualified person in accordance with all relevant legislation. Ambient operating temperature of 0°C to 25°C. If maximum operating temperature is exceeded luminaire will automatically dim / switch off. Terminal blocks are rated to 16A unless stated otherwise. The light source contained in this luminaire shall only be replaced by the manufacturer or his service agent or a similar qualified person.

**LUMINAIRES WITH EMERGENCY PACK:** When supply is isolated battery output terminals may be live if battery is connected. Isolate mains and battery before servicing. Emergency luminaires require unswitched live connection taken from same phase as switched supply. When unswitched supply is connected status indicator illuminates green, when unswitched supply is disconnected indicator extinguishes and luminaire operates in emergency mode. 24 hour charge period required before undertaking full discharge test. Emergency test sheets provided should be used to record all emergency tests. Batteries should be replaced when 3 hour duration is not met. Excessive switching of permanent live may result in premature battery failure. Battery electrolyte can be harmful to eyes / open wounds, do not puncture, if electrolyte touches skin / eyes flush with water. Do not incinerate batteries.

1.

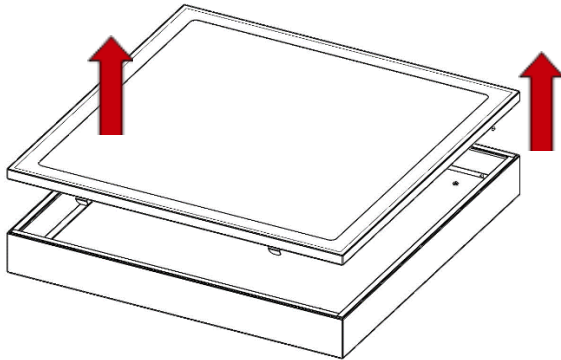

Unpack luminaire and carefully remove the frame from the main body. There are 4no. leaf springs attached to the frame.

2.

The luminaire is packed with the frame springs engaged in the main body. The frame has x2 tethers inside that are not attached to the tray for ease of initial installation. These will be connected later on.

3.

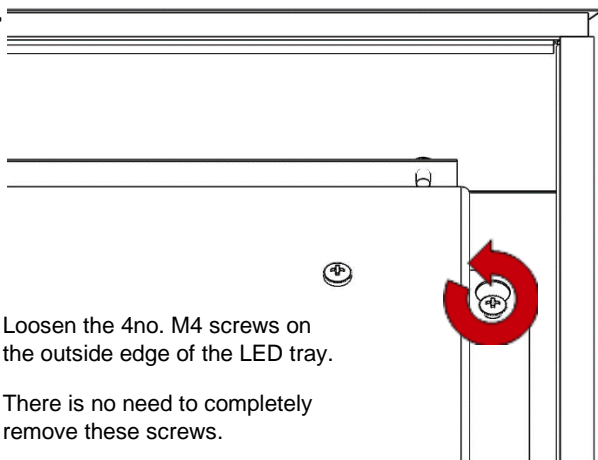

Loosen the 4no. M4 screws on the outside edge of the LED tray.

There is no need to completely remove these screws.

4.

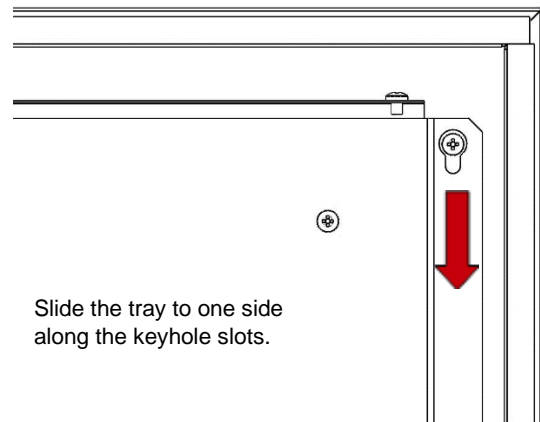

Slide the tray to one side along the keyhole slots.

5.

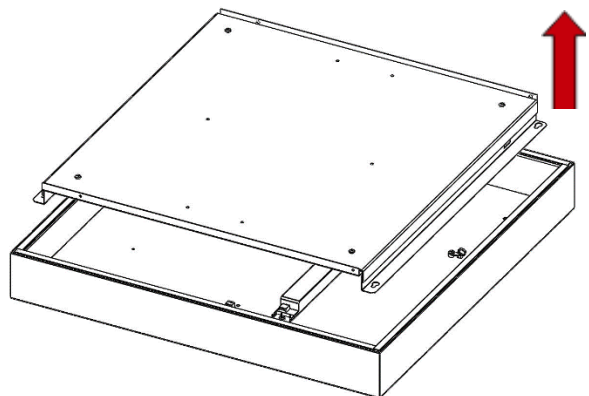

Partially lift the tray from the housing.

6.

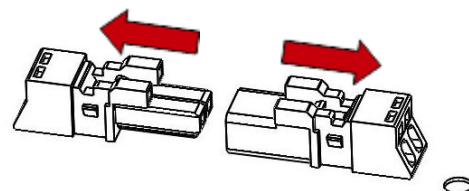

**NOTE:** There is a plug and socket connection between the main housing and the LED tray that must be disconnected before fully removing the tray

## MOD Surface Installation

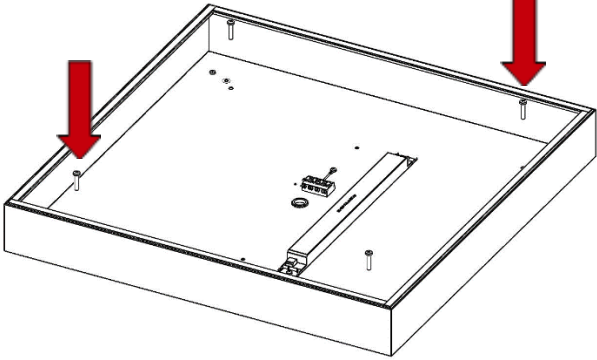
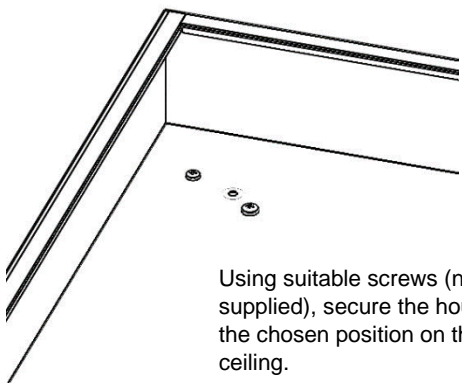
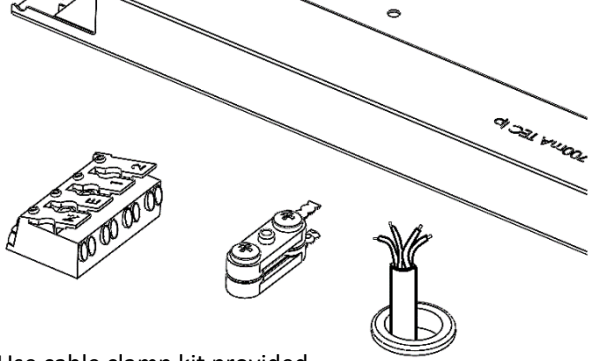
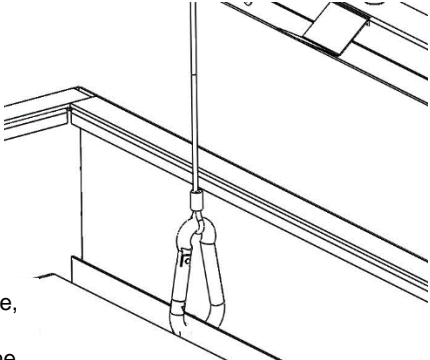
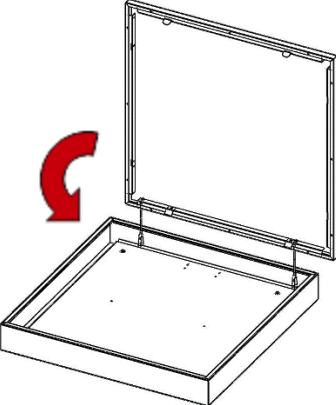
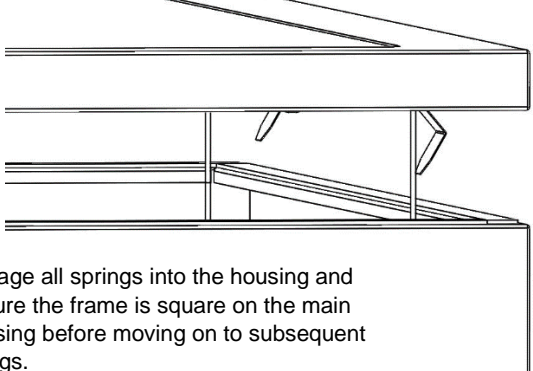
<p>7.</p> 	<p>8.</p>  <p>Using suitable screws (not supplied), secure the housing to the chosen position on the ceiling.</p>
<p>9.</p> <p>Feed the mains cable in through the grommated hole in the rear of the housing. Wire into the marked terminals as required.</p> <p>NOTE: Side cable entries are available upon special request.</p>	<p>10.</p>  <p>Use cable clamp kit provided.</p>
<p>11.</p> <p>To replace the tray, reverse steps 3 – 6 ensuring the plug and socket is reconnected in step 6.</p>	<p>12.</p>  <p>To replace the frame, attach the 2no. Karabiner clips to the holes in the gear tray</p>
<p>13.</p> <p>Swing the frame up on to the main housing. The frame tethers should be at an angle to ensure they do not cover the LED board.</p> 	<p>14.</p>  <p>Engage all springs into the housing and ensure the frame is square on the main housing before moving on to subsequent fittings.</p>

## MOD Surface Installation

15.  
RLS

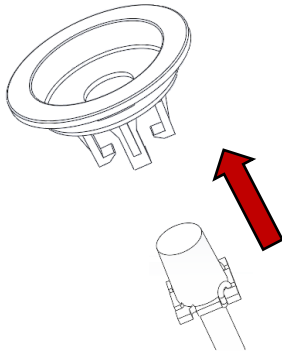

Once housing is installed, insert sensor into sensor housing located in frame.

16.

### Maintenance

① Disconnect luminaire before undertaking any maintenance or cleaning.

② Cleaning should be undertaken on external parts of the luminaire only using a slightly damp lint free cloth.

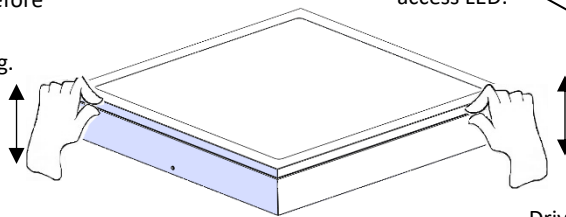

③ Remove cover by hand. No tools required.

Remove touch proof cover and screws to access LED.

④ Use a pan pozi screwdriver when removing components.

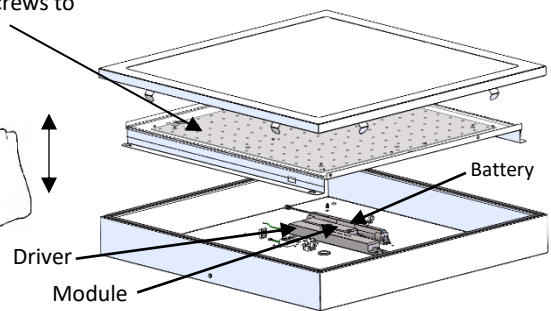

⑤ Please contact Dextra for assistance with spare component supply.