

220-240V / 50-60Hz  
IP20

**Terminal Labelling:**

**Power**

L1	Switched Live
E	Earth
N	Neutral

**Emergency**

L2	Unswitched Live
DA/AT3	DALI Autotest
DA/AT3	DALI Autotest

**Dimming**

-/D1/DA	Analogue/DSI/DALI
+/D2/DA	Analogue/DSI/DALI
L3	Switch Dim / Corridor Function

**WARNING:** Luminaire must be earthed. Risk of electric shock from LED boards if operated with cover removed. Installation / operation outside of luminaires intended scope invalidates warranty. Suitable only for domestic / light industrial / industrial applications within the scope of EN55015. Tested to compliance with BSEN 60598: specification for general requirements and tests. Must be installed by a suitably qualified person in accordance with all relevant legislation. Ambient operating temperature of 0°C to 25°C. If maximum operating temperature is exceeded luminaire will automatically dim / switch off. Terminal blocks are rated to 16A unless stated otherwise. The light source contained in this luminaire shall only be replaced by the manufacturer or his service agent or a similar qualified person. **LUMINAIRES WITH EMERGENCY PACK:** When supply is isolated battery output terminals may be live if battery is connected. Isolate mains and battery before servicing. Emergency luminaires require unswitched live connection taken from same phase as switched supply. When unswitched supply is connected status indicator illuminates green, when unswitched supply is disconnected indicator extinguishes and luminaire operates in emergency mode. 24 hour charge period required before undertaking full discharge test. Emergency test sheets provided should be used to record all emergency tests. Batteries should be replaced when 3 hour duration is not met. Excessive switching of permanent live may result in premature battery failure. Battery electrolyte can be harmful to eyes / open wounds, do not puncture, if electrolyte touches skin / eyes flush with water. Do not incinerate batteries.

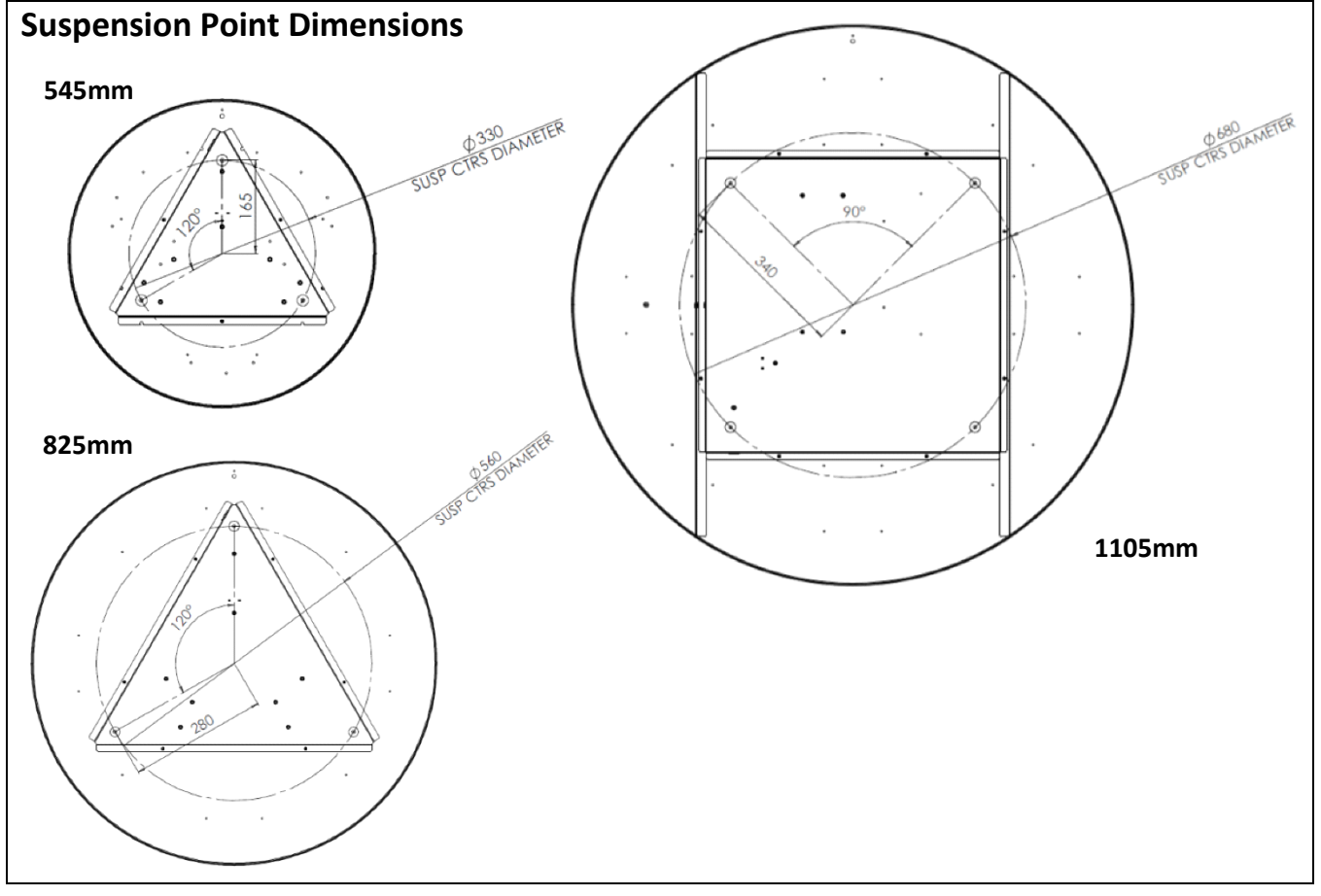
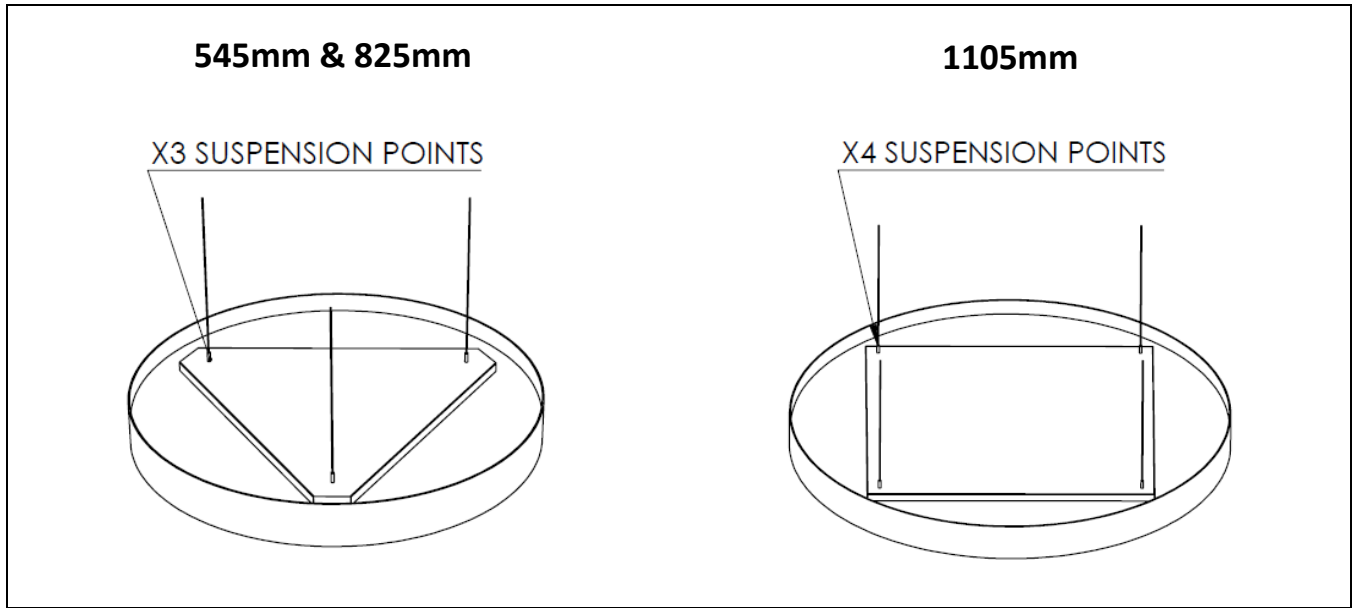

## SUSPENSION KIT

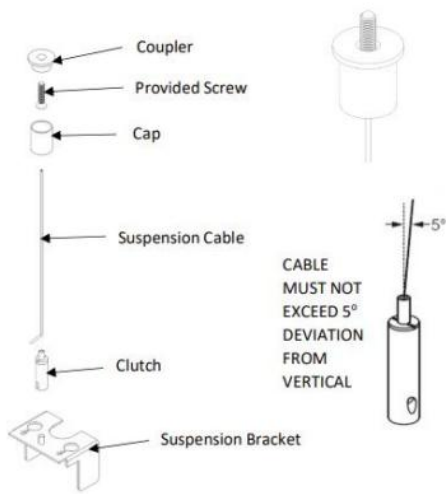

- Mount the couplers to the ceiling using the screws provided in the suspension kit.
- Pass the suspension cables through the caps.
- Tighten the caps to the couplers already mounted to the ceiling.
- Tighten the clutches to the suspension brackets.
- Lift the luminaire and attach the loose ends of the cables through the top of the clutch until the cable comes through the hole on the side of the clutch.
- Pull on the cables to lift luminaire closer to the ceiling and set desired height.
- Level the luminaire ensuring each suspension cable is under tension.
- Trim the excess suspension cable.

1.

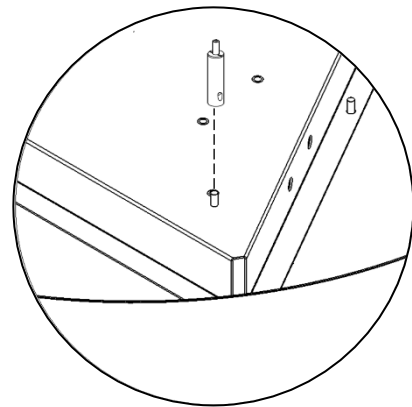
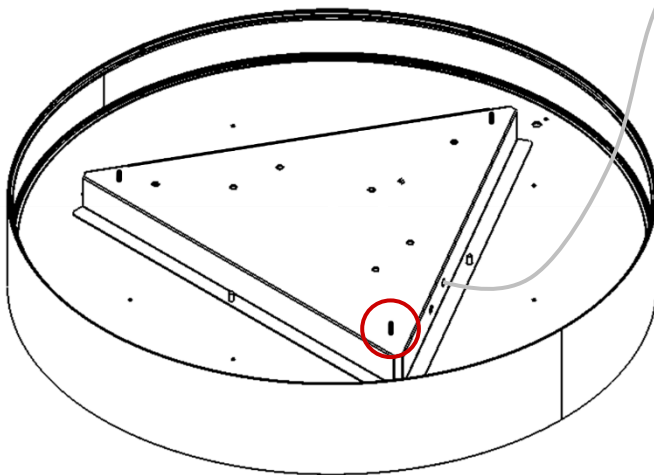

Screw the clutches to the clutch studs, located on the rear tray.

2.

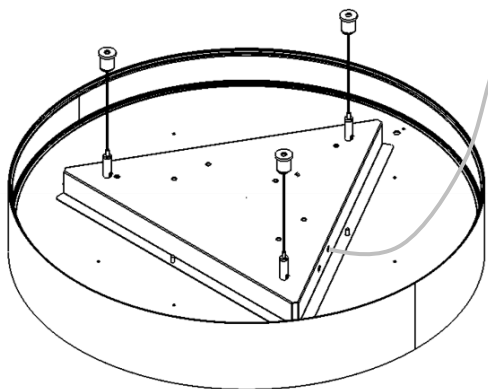

Lift the luminaire into place and level, ensuring each suspension cable is under tension. Then trim the excess suspension cable.

3.

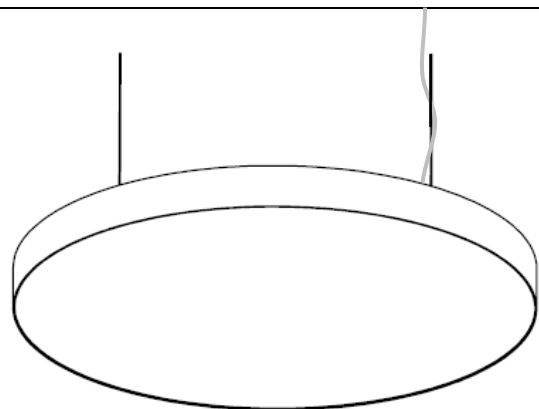

All suspended variants are supplied with a pre-fitted 3.5m flex. Once connected, test to complete installation.

## Maintenance Guide

1. Disconnect the luminaire before undertaking any maintenance or cleaning.
2. Cleaning should be undertaken on external parts of the luminaire only, using a slightly damp, lint-free cloth.
3. Remove the front diffuser to access the LED circuit and remove the rear tray to access the driver and terminals.

