

## Runway Curve Installation

220-240V / 50-60Hz  
IP20

**Terminal Labelling:**

**Power**

L1 Switched Live  
E Earth  
N Neutral

**Emergency**

L2 Unswitched Live  
DA/AT3 DALI Autotest  
DA/AT3 DALI Autotest

**Dimming**

-/D1/DA Analogue/DSI/DALI  
+/D2/DA Analogue/DSI/DALI  
L3 Switch Dim / Corridor Funct



**WARNING:** Luminaire must be earthed. Risk of electric shock from LED boards if operated with cover removed. Installation / operation outside of luminaires intended scope invalidates warranty. Suitable only for domestic / light industrial / industrial applications within the scope of EN55015. Tested to compliance with BSEN 60598: specification for general requirements and tests. Must be installed by a suitably qualified person in accordance with all relevant legislation. Ambient operating temperature of 0°C to 25°C. If maximum operating temperature is exceeded luminaire will automatically dim / switch off. Terminal blocks are rated to 16A unless stated otherwise. The light source contained in this luminaire shall only be replaced by the manufacturer or his service agent or a similar qualified person. **LUMINAIRES WITH EMERGENCY PACK:** When supply is isolated battery output terminals may be live if battery is connected. Isolate mains and battery before servicing. Emergency luminaires require unswitched live connection taken from same phase as switched supply. When unswitched supply is connected status indicator illuminates green, when unswitched supply is disconnected indicator extinguishes and luminaire operates in emergency mode. 24 hour charge period required before undertaking full discharge test. Emergency test sheets provided should be used to record all emergency tests. Batteries should be replaced when 3 hour duration is not met. Excessive switching of permanent live may result in premature battery failure. Battery electrolyte can be harmful to eyes / open wounds, do not puncture, if electrolyte touches skin / eyes flush with water. Do not incinerate batteries.

1.



Unpack the fitting. The luminaire will arrive as a complete unit, no disassembly required.

2.

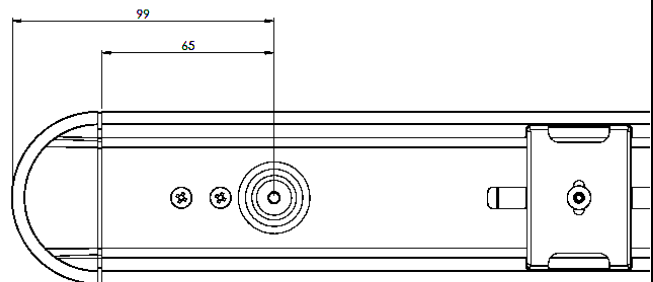

The cable entry point is the same across all variants.

3.

**SUSPENSION POINTS:**

There is some tolerance in the suspension points shown; this can be adjusted on the luminaire if required.

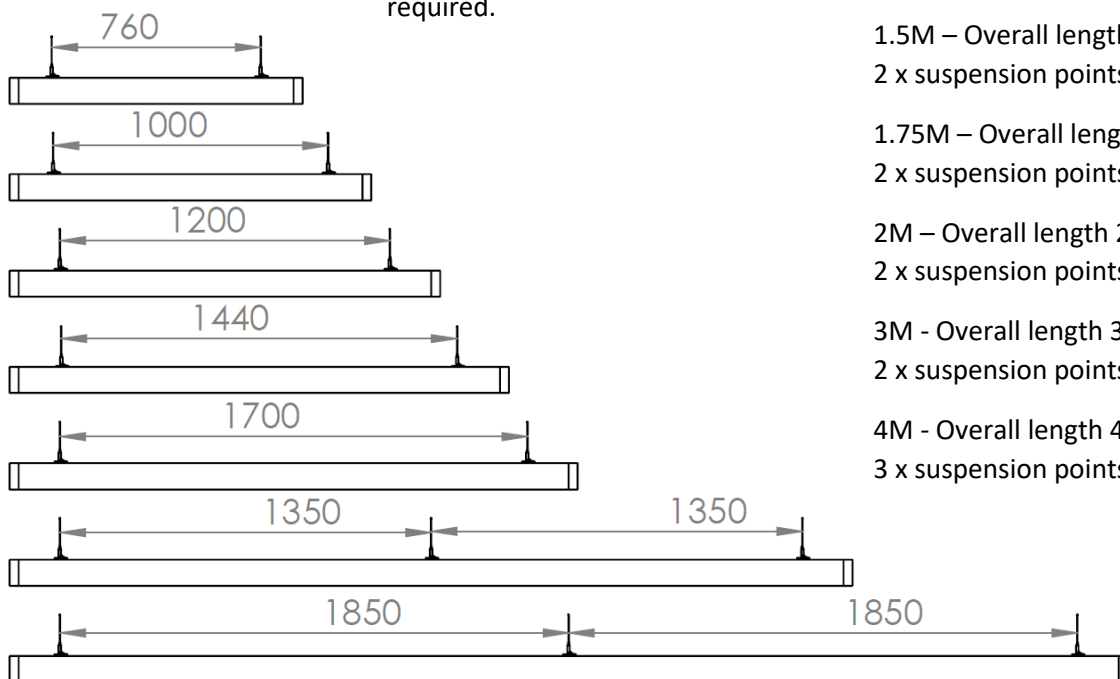

1M – Overall length 1068mm  
2 x suspension points required.

1.25M – Overall length 1318mm  
2 x suspension points required.

1.5M – Overall length 1568mm  
2 x suspension points required.

1.75M – Overall length 1818mm  
2 x suspension points required.

2M – Overall length 2068mm  
2 x suspension points required.

3M - Overall length 3068mm  
2 x suspension points required.

4M - Overall length 4068mm  
3 x suspension points required.

## Runway Curve Installation

4.

Attach the suspension wire to the spring brackets ready to be attached to the trunking.

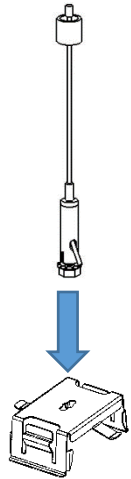

5.

Secure the suspension drops as shown in the marked positions.

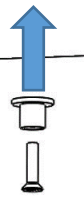

Screw the suspension wire and clutch into the mounting fixture.

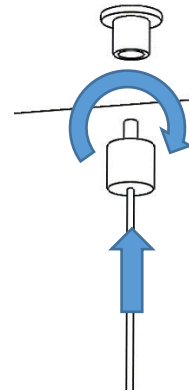
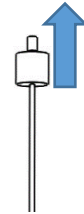

6.

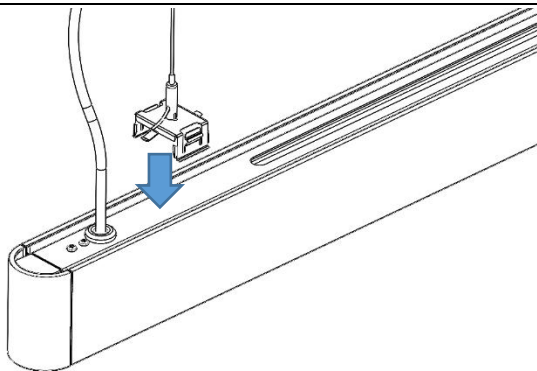

Snap the spring brackets onto the trunking and adjust until the suspension wires hang vertically.

7.

Run the lead adjacent to the suspension wire. Cable tie the two together.

Establish an electrical connection to the luminaire

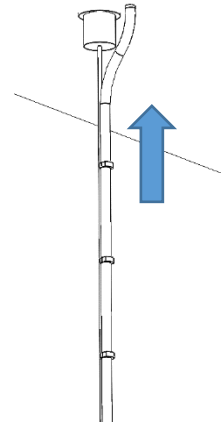

8.

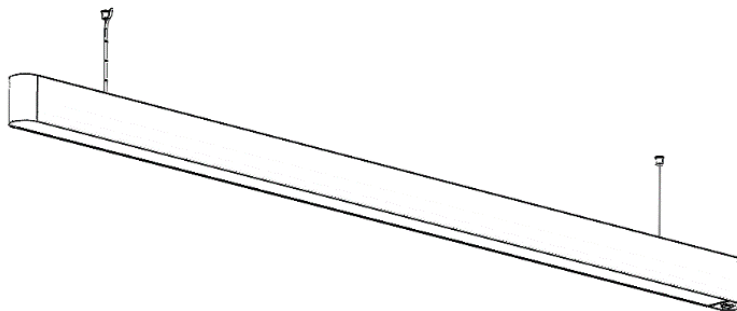

Installation is complete

## Runway Curve Installation

9. Please note the following diagrams when wiring a luminaire with a pre-wired flex:

### STANDARD

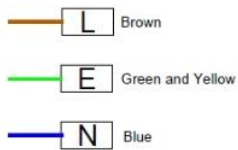

### SWITCH DIM

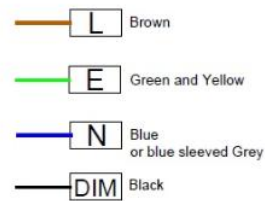

### DALI/DSI

FLEX: Brown/GY/Blue/White/Red

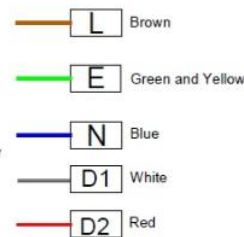

### DOUBLE SWITCHED

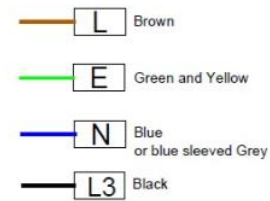

### EMERGENCY

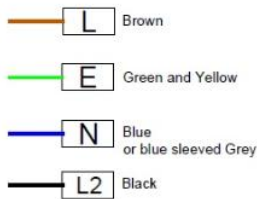

### SWITCH DIM

FLEX: Brown/GY/Blue/Black/Grey

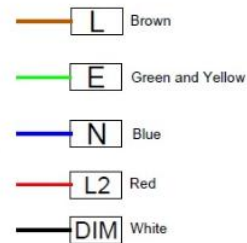

### DALI/DSI

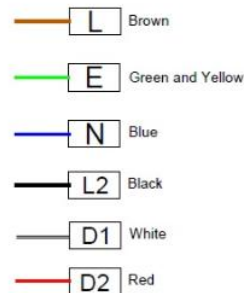

### DOUBLE SWITCHED

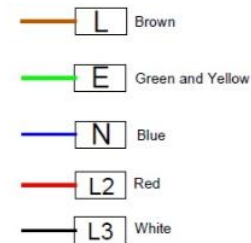

10.

### Maintenance

- 1 Disconnect luminaire before undertaking any maintenance or cleaning.
- 2 Cleaning should be undertaken on external parts of the luminaire only using a slightly damp lint free cloth.
- 3 Use a flat headed screwdriver to gently open the diffuser. Start at centre and pull down towards ends
- 4 Release geartray from housing using a flat screwdriver to release clips.
- 5 Disconnect starter loom.
- 6 Remove plastic rivets to separate the two gear trays.
- 7 Use a pan pozi screwdriver to remove components.
- 8 Please contact Dextra for assistance with spare component supply.

