

Rubini Accent / Recessed Installation

220-240V / 50-60Hz
IP20

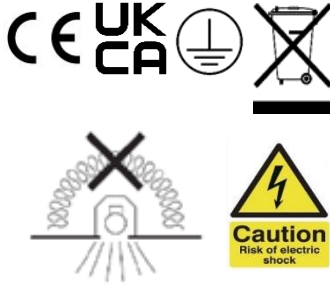

WARNING: Luminaire must be earthed. Risk of electric shock from LED boards if operated with cover removed. Installation / operation outside of luminaires intended scope invalidates warranty. Suitable only for domestic / light industrial / industrial applications within the scope of EN55015. Tested to compliance with BSEN 60598: specification for general requirements and tests. Must be installed by a suitably qualified person in accordance with all relevant legislation. Ambient operating temperature of 0°C to 25°C. If maximum operating temperature is exceeded luminaire will automatically dim / switch off. Terminal blocks are rated to 16A unless stated otherwise. The light source contained shall only be replaced by the manufacturer or his service agent or a similar qualified person. **LUMINAIRES WITH EMERGENCY PACK:** When supply is isolated battery output terminals may be live if battery is connected. Isolate mains and battery before servicing. Emergency luminaires require unswitched live connection taken from same phase as switched supply. When unswitched supply is connected status indicator illuminates green, when unswitched supply is disconnected indicator extinguishes and luminaire operates in emergency mode. 24 hour charge period required before undertaking full discharge test. Emergency test sheets provided should be used to record all emergency tests. Batteries should be replaced when 3 hour duration is not met. Excessive switching of permanent live may result in premature battery failure. Battery electrolyte can be harmful to eyes / open wounds, do not puncture, if electrolyte touches skin / eyes flush with water. Do not incinerate batteries.

Terminal Labelling:

Power	
L / 1	Switched Live
E /	Earth
N	Neutral
Emergency	
L2 / 2	Unswitched Live
DA/AT3	DALI Autotest
DA/AT3	DALI Autotest
Dimming	
-D1/DA	Analogue/DSI/DALI
+D2/DA	Analogue/DSI/DALI
SD	Switch Dim / Corridor Function

1.

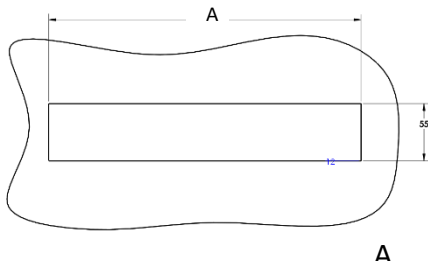

7 Cell	304mm
14 Cell	584mm

Ceiling thickness needed to be between 4-25mm

2.

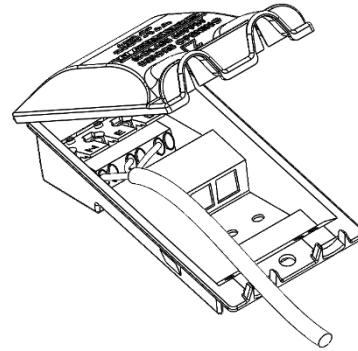

Wire into the allocated terminals.

3.

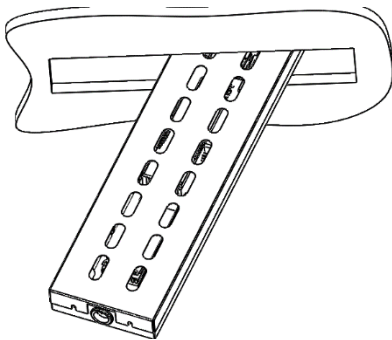

Lift remote box/ remote driver up through gap.

4.

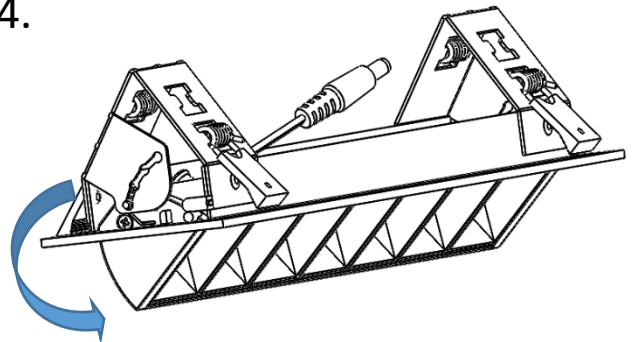

Determine what angle you want the fitting to point and rotate the luminaire into the required position.

5.

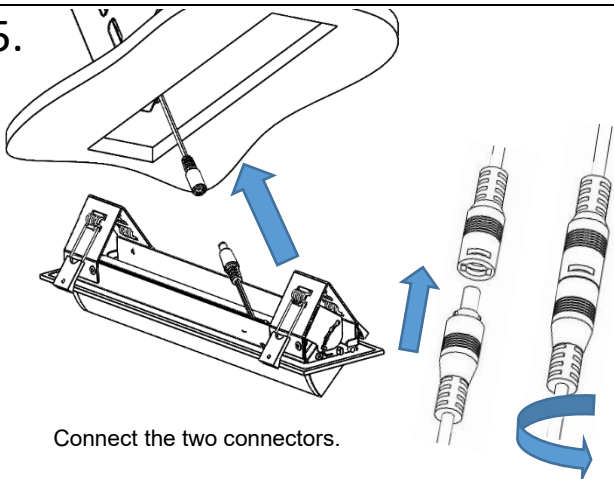

Connect the two connectors.

6.

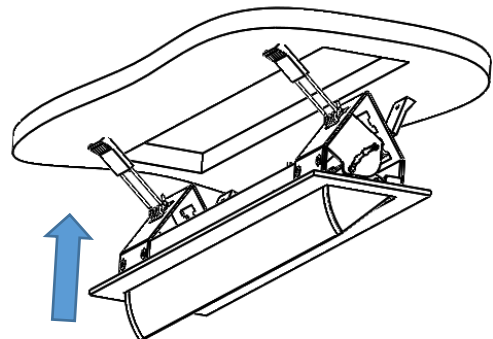

Lift up the springs and raise fitting into the cut out. Use a pattress in the ceiling if required.

Rubini Accent / Recessed Installation

Maintenance

- 1 Disconnect luminaire before undertaking any maintenance or cleaning.
- 2 Cleaning should be undertaken on external parts of the luminaire only using a slightly damp lint free cloth.
- 3 Use a flat headed screwdriver to lever off end cap then slide fitting out from frame.
- 4 Use a pan pozi screwdriver to remove endcap.
- 5 Remove baffle to reveal lens.
- 6 Using same screwdriver remove lens from LED circuit.
- 7 Use a pan pozi screwdriver to remove components.
- 8 Please contact Dextra for assistance with spare component supply.

