

LED4 LA3R Installation

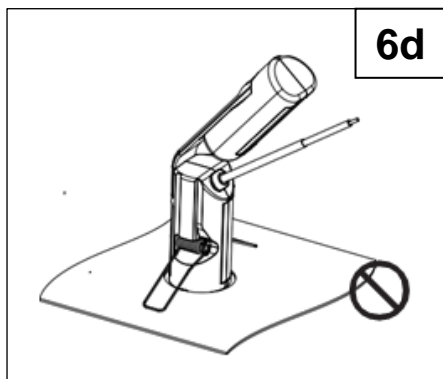
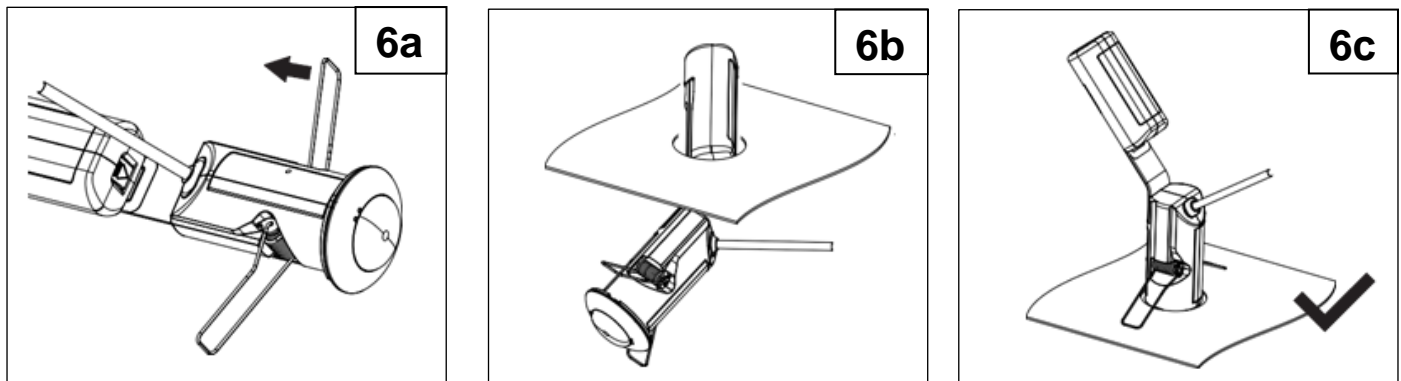
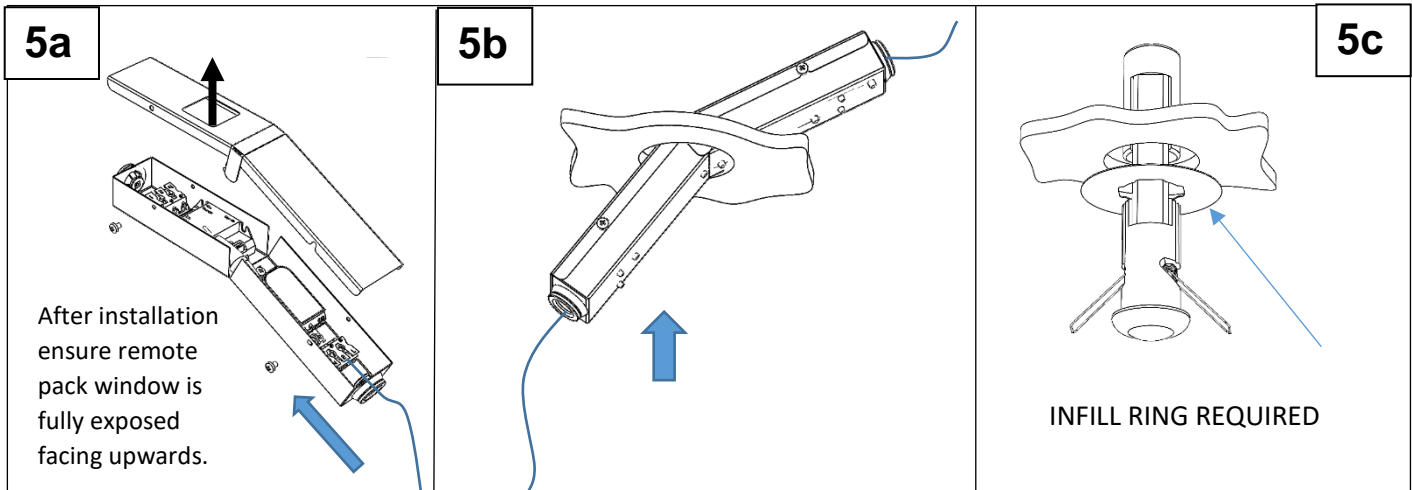

Safety Note

Any modification may be carried out exclusively by qualified personnel and according to application provisions and regulations.

The luminaire must always be disconnected from the mains whenever it is being worked on.

The manufacturer shall not be liable for any damage resulting from inappropriate modifications to the luminaire or faulty installation.

A strain relief is required for proper connection of the cable.

