

220-240V / 50-60Hz

IP65

IK07



Terminal Labelling:

Power	
L / 1	Switched Live
E / 0	Earth
N	Neutral
Emergency	
L2 / 2	Unswitched Live
DA/AT3	DALI Autotest
DA/AT3	DALI Autotest
Dimming	
-/D1/DA	Analogue/DSI/DALI
+/D2/DA	Analogue/DSI/DALI
SD	Switch Dim / Corridor Function

WARNING: Luminaire must be earthed. Risk of electric shock from LED boards if operated with cover removed. Installation / operation outside of luminaires intended scope invalidates warranty. Suitable only for domestic / light industrial / industrial applications within the scope of EN55015. Tested to compliance with BSEN 60598: specification for general requirements and tests. Must be installed by a suitably qualified person in accordance with all relevant legislation. Ambient operating temperature of 0°C to 25°C. If maximum operating temperature is exceeded luminaire will automatically dim / switch off. Terminal blocks are rated to 16A unless stated otherwise. The light source contained in this luminaire shall only be replaced by the manufacturer or his service agent or a similar qualified person. **LUMINAIRES WITH EMERGENCY PACK:** When supply is isolated battery output terminals may be live if battery is connected. Isolate mains and battery before servicing. Emergency luminaires require unswitched live connection taken from same phase as switched supply. When unswitched supply is connected status indicator illuminates green, when unswitched supply is disconnected indicator extinguishes and luminaire operates in emergency mode. 24 hour charge period required before undertaking full discharge test. Emergency test sheets provided should be used to record all emergency tests. Batteries should be replaced when 3 hour duration is not met. Excessive switching of permanent live may result in premature battery failure. Battery electrolyte can be harmful to eyes / open wounds, do not puncture, if electrolyte touches skin / eyes flush with water. Do not incinerate batteries.

1. Surface & Suspended



Fasten mounting brackets to the ceiling first, with the centre distance as following:

- 340mm +/-70mm apart for the 600mm fitting
- 830mm +/-70mm apart for the 1200mm fitting
- 940mm +/-70mm apart for the 1500mm fitting

2. Surface & Suspended

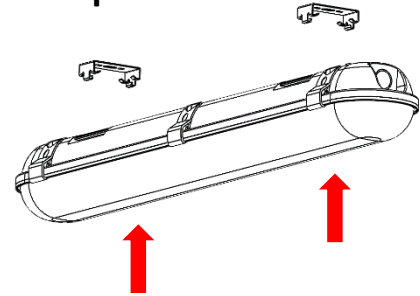

Lift fitting up to the surface mount clips and push into place.

1. Trunking & Conduit

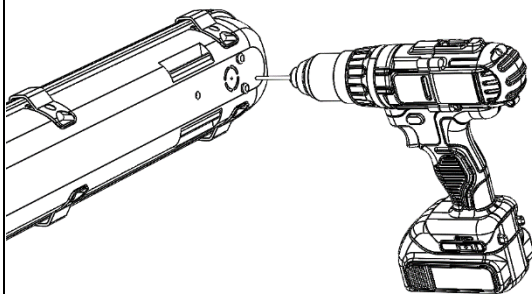

Drill holes in rear once gear tray and diffuser are removed as per step 3, taking care not to be in a position that may clash with components or clips.

2. Trunking & Conduit

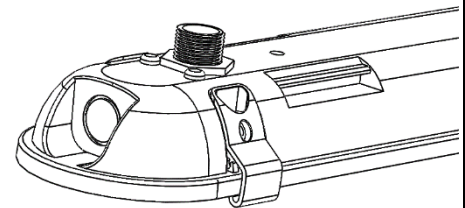

Use Locking Nut and brass bush to fix the fitting to the conduit or trunking.

Note: The installer must re-seal if IP rating is required

3.

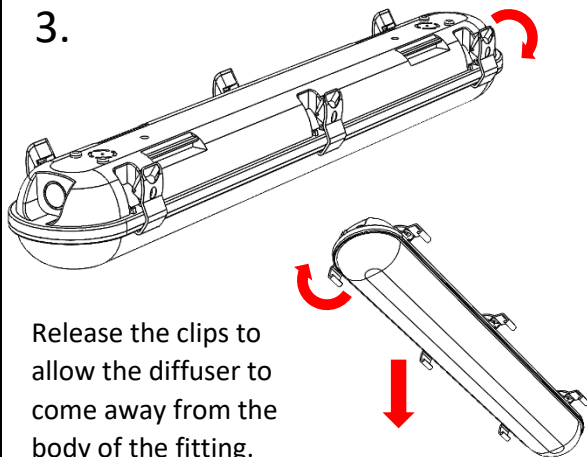

Release the clips to allow the diffuser to come away from the body of the fitting.

4.

Compress the internal clips to release the gear tray from the body of the fitting and allow fitting to hang on tethers.

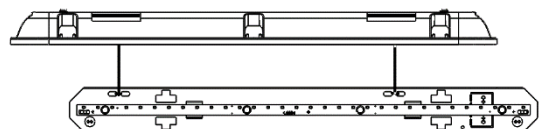
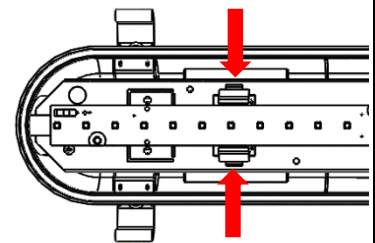

Siren Installation

5.

Feed the mains cable through the cable entry, making sure that the IP rating is maintained, and wire into the appropriate terminals.

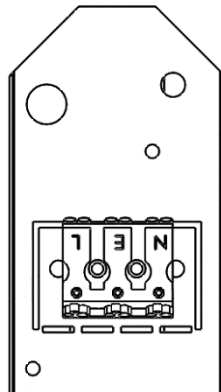

6.

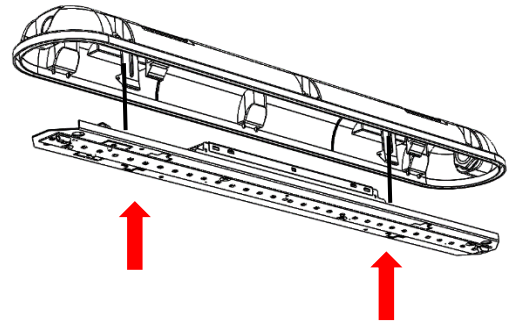

Push tray back onto the clips.

7.

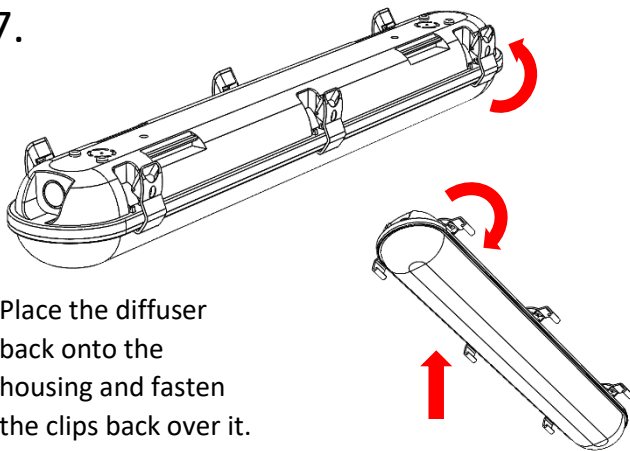

Place the diffuser back onto the housing and fasten the clips back over it.

8.

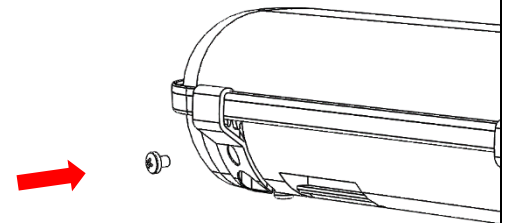

Using the supplied screws fasten the end 4 clips to lock them in place.

NOTES:

- Full IP ratings only apply when luminaire is mounted horizontally facing downward on a ceiling internally or under a canopy externally.
- It is the responsibility of the installer to ensure the IP ratings are maintained during installation of the fitting.
- This luminaire is only suitable for domestic, light industrial and industrial environments which are within the scope of EN 55015.
- Not for use in hazardous areas, areas of excessive heat or where airborne fatty substances may be present.
- Operating temperature is 0°C to 25°C. If the temperature exceeds the drivers maximum TA there is a safety mechanism where the driver will either dim or switch off to allow it to cool.

Siren Installation

Maintenance

- 1 Disconnect luminaire before undertaking any maintenance or cleaning.
- 2 Cleaning should be undertaken on external parts of the luminaire only using a slightly damp lint free cloth.
- 3 To access fitting use a flat head screwdriver to remove clips along housing.
- 4 Use a pan pozi screwdriver to remove components.
- 5 Please contact Dextra for assistance with spare component supply.

